

**ANTIBODY REPERTOIRES AND PATHOGEN
RECOGNITION: THE ROLE OF GERMLINE DIVERSITY
AND SOMATIC HYPERMUTATION.**

by

Mihaela L. Oprea

M.D., University of Medicine and Pharmacy, Timisoara, Romania, 1992

M.S., Computer Science, University of New Mexico, Albuquerque, 1996

Dissertation

Submitted in Partial Fulfillment of the
Requirements for the Degree of

**Doctor of Philosophy
Computer Science**

The University of New Mexico
Albuquerque, New Mexico

May 1999

©1999, Mihaela L. Oprea

**ANTIBODY REPERTOIRES AND PATHOGEN
RECOGNITION: THE ROLE OF GERMLINE DIVERSITY
AND SOMATIC HYPERMUTATION.**

by

Mihaela L. Oprea

Abstract of Dissertation

Submitted in Partial Fulfillment of the
Requirements for the Degree of

**Doctor of Philosophy
Computer Science**

The University of New Mexico
Albuquerque, New Mexico

May 1999

ANTIBODY REPERTOIRES AND PATHOGEN RECOGNITION: THE ROLE OF GERMLINE DIVERSITY AND SOMATIC HYPERMUTATION.

by

Mihaela L. Oprea

M.D., University of Medicine and Pharmacy, Timisoara, Romania, 1992

M.S., Computer Science, University of New Mexico, Albuquerque, 1996

Ph.D., Computer Science, University of New Mexico, 1999

Abstract

The classical view of the immune system is that it constructs its receptors so as to recognize as many molecular shapes as possible. This mechanism is anticipatory in the sense that no prior knowledge of the pathogens needs to go in the construction of the immune receptors that can bind these pathogens. However, at any point in time, the immune system can only circulate a limited number of lymphocytes, and thereby a limited variety of receptors, through the body. Considering this, it seems crucial that the immune system optimizes the use of its limited resources by somehow placing its receptors "strategically" in the space of possible shapes.

Using both analytical and computer simulation results I show:

- How antibody repertoires optimize their structure for maximal coverage of given pathogen sets;
- The extent to which this optimization occurs as a function of the relative sizes of pathogen and antibody sets, as well as their relative rates of evolution;
- That the specificity with which individual pathogens are recognized increases only very slowly with the size of the antibody repertoire.

I further show that compositional biases responsible for targeting somatic hypermutation to the antigen-binding regions of individual antibody genes appeared very early in phylogeny. This

suggests that evolvability under somatic hypermutation has been an important selection pressure in the evolution of immune systems.

As a contribution to the effort for identifying the mechanism responsible for somatic hypermutation,

- I provide evidence that the compositional biases in non-immunoglobulin genes would minimize the effect of somatic hypermutation in these genes. I propose that the mechanisms responsible for germline mutation and somatic hypermutation might be related.
- I provide improved methods for estimating mutation rates. The assessment of the effect that various genetic manipulations have on the rate of somatic hypermutation can be improved by using these methods.

Contents

Abstract	iv
List of Figures	ix
List of Tables	xi
1 Introduction	1
1.1 Rationale	1
1.2 Brief introduction to the immune system	3
1.2.1 Innate versus adaptive immunity	3
1.2.2 The development of an immune response	3
1.2.3 Self-nonsel self discrimination	5
1.2.4 The anticipatory capacity of the immune system	6
1.2.5 Structural components of the immune receptors	9
2 How much can germline diversity do?	12
2.1 Shape space coverage with distance-dependent matching	13
2.1.1 Model	14
2.1.2 Lower bound on the evolved fitness	16
2.1.3 Upper bound on the evolved fitness	17
2.1.4 The fitness of evolved libraries	18
2.1.5 The strategy of evolved libraries	19
2.2 Shape space coverage with other matching rules	24
2.2.1 Lower bound on the fitness	26
2.2.2 The fitness and structure of evolved libraries	27
2.2.3 Implications for random antibody libraries	28

3	Somatic hypermutation targets the antigen-binding regions of antibody genes	31
3.1	Calculating the predicted replacement mutability of a sequence	34
3.2	All human immunoglobulin <i>V</i> -region sequences have higher average replacement mutability of CDR nucleotides than of FR nucleotides	35
3.3	Statistical analysis on the level of individual sequences	37
3.4	Contribution of nucleotide composition, codon composition and codon usage bias to the predicted FR and CDR replacement mutability of human V_H sequences	44
3.5	Are human <i>V</i> -region sequences optimized for somatic hypermutation?	46
3.6	Similar mutability pattern in <i>V</i> genes from other species	49
3.7	Higher predicted replacement mutability of T cell receptor CDRs than T cell receptor FRs	53
4	Non-immunoglobulin genes would have low mutability under somatic hypermutation	56
4.1	In non-immunoglobulin genes, predicted mutability is correlated with A/T content	57
4.2	A significant proportion of non-immunoglobulin genes also have codon bias consistent with low mutability under somatic hypermutation	60
5	Mutants must be generated and selected in a step-wise fashion during the germinal center reaction	63
5.1	Affinity maturation during the germinal center reaction	63
5.2	One-pass selection model of the germinal center reaction	65
5.2.1	Basic model	65
5.2.2	Amplification of high affinity cells in the memory population is a logarithmic function of their selection coefficient	68
5.3	Implications for affinity maturation in the germinal centers	71
6	Mutation rate estimation	74
6.1	Cell division, cell cycle times	74
6.2	Computational model of a growing culture of cells	76
6.3	Mean number of mutants in a culture of size N	78
6.4	Continuum approximation of the Luria-Delbrück distribution	85
6.4.1	Cell-cycle correction to the continuum Luria-Delbrück distribution for 2-phase models of the cell cycle	87
6.4.2	Inference procedures.	89

6.5	Constructing confidence intervals for the mean mutation rate in cultures of cells that have a gamma-distributed cell cycle time	90
6.6	Estimating mutation rates in real cultures	92
6.6.1	Bacterial growth	92
6.6.2	Emergence of high affinity mutants in the germinal centers	93
7	Conclusions	97
7.1	Summary of results	98
7.1.1	Germline diversity does not contribute to the direct recognition of pathogens	98
7.1.2	Immunoglobulin genes evolved plasticity for somatic hypermutation	99
7.1.3	The efficiency of affinity maturation can only be explained by multiple rounds of mutation-selection-expansion of lymphocytes	100
7.1.4	Improved methods for mutation rate estimation	100
7.2	Future work	101
7.3	In lieu of closing	102
A	Non-immunoglobulin genes	103
	References	109

List of Figures

1.1	Schematic structure of the immunoglobulin molecule	7
1.2	Processes leading to the synthesis of the immunoglobulin heavy chain.	7
1.3	Schematic representation of the gene conversion	9
1.4	Schematic view of the variable part of an antibody molecule	10
2.1	Scaling of the fitness with respect to the antibody set size	18
2.2	Expected fitness of evolved libraries with respect to a random pathogen	22
2.3	Dependence of the z-statistic on the training set size	24
2.4	Scaling of the fitness with respect to the antibody set size for the random energy model	27
3.1	Scatter plot of the average FR vs. CDR mutability of human V region genes	35
3.2	Contour plot of the predicted average FR vs. CDR mutability of $V_{\kappa}A2$ variants . .	38
3.3	Contour plot of the predicted average FR vs. CDR mutability of VH1-18 variants .	39
3.4	Contour plot of the predicted average FR vs. CDR mutability of VH2-26 variants .	40
3.5	Contour plot of the predicted average FR vs. CDR mutability of VH6-1 variants . .	41
3.6	Contour plot of the average FR vs. CDR mutability over sets of variants of human V_H sequences	45
3.7	The predicted average replacement mutability of CDR vs. FR nucleotides for sheep V_{λ} , and <i>Heterodontus</i> and rainbow trout V_H	49
3.8	Scatter plot of the predicted FR vs. CDR nucleotide mutability values for the set of human TCR_{α} and TCR_{β} sequences	54
4.1	Average nucleotide mutability versus the G/C content of the sequence	58
4.2	Average replacement mutability per nucleotide versus the G/C content of the sequence. Each data point represents one non-immunoglobulin sequence.	59

4.3	Histogram of the normalized ranks of the 140 non-immunoglobulin genes among their translationally neutral variants.	60
5.1	Sketch of the germinal center reaction	64
5.2	Output fluxes of the low and high affinity cells as a function of time	70
6.1	Genealogical trees that can be realized in a four-cell culture	84
6.2	Δ_U (closed circles) and Δ_L (open circles) as a function of the mutation rate for a gamma-distribution of order $q = 10$	91

List of Tables

3.1	Normalized ranks of individual V_H sequences.	42
3.1	Normalized ranks of individual V_H sequences (continued).	43
3.2	Normalized rank of the ratio between the predicted average CDR and FR mutability of observed germline sequences among their 2-, 10- and 50-mutant neighbors. . . .	47
3.2	Normalized rank of the ratio between the predicted average CDR and FR mutability of observed germline sequences among their 2-, 10- and 50-mutant neighbors (continued).	48
3.3	Normalized ranks of individual sheep V_λ sequences.	52
4.1	Correlation between mutability and A/T content	58
6.1	Mean proportion of mutants in cultures in which cells have gamma-distributed cell cycle time.	83
6.2	Mean proportion of mutants in cultures in which the cell cycle time is distributed as a shifted exponential.	83
6.3	Fit of the b parameter	89
6.4	Linear regression of Δ_L and Δ_U as functions of the mutation probability.	92

Chapter 1

Introduction

1.1 Rationale

The capacity to mount an immune response is essential for the survival of organisms, as demonstrated by the fatal outcome of immunodeficiency syndromes, genetic or acquired. No antibiotic treatment can circumvent the lack of a functional immune system. However, the immune system might fail to protect the organism. Sometimes the cause of failure is an inappropriate handling of pathogens, some other times the pathogens just act too fast. In either of these circumstances, the pathogens spread and cause damage before the immune system can initiate an efficient response. The response time of the immune system is thus of vital importance. It is essentially determined by the the frequency and efficacy of the responding cells. Given these considerations, we would expect that the immune system learns what pathogens look like, both in the evolution of the species, as well as during the immune responses that take place during the life time of an organism. Indeed, in all species in which an immune system has been described, we find gene libraries of immune receptors, as well as mechanisms, such as somatic mutation that diversify the immune receptors throughout the lifetime of an organism. Immune receptor libraries consist of gene fragments that are used in a mutually exclusive fashion on different cells. Thus, an organism possesses multiple genetically-encoded receptor fragments, which can evolve independently of each other. Being encoded in the genome, these immune receptor genes may be subject to optimization, through mutation and selection on the basis of the survival of the organism. Moreover, the immune system also learns while an immune response is happening. The immune receptor genes undergo targeted mutation and selection on the basis of binding to pathogens. Mutations that are introduced in the gene during this process only affect the individual immune cells (lymphocytes), and are not transmitted to the offspring.

We thus have a basic understanding of the mechanisms that create diverse immune receptors. This is, however, not sufficient. What is crucial for the success of an immune reaction is the presence of the right receptor with the right frequency at the time of the pathogenic challenge. We therefore need to understand the role that these different mechanisms play in creating the immune repertoire.

There are a number of constraints that the immune repertoire seems to obey. Probably the most puzzling one is that it has to be capable of recognizing a wealth of molecules. Although it is not known, it is believed that there are many more possible molecular shapes than there are immune receptors in the body. Many animal studies use artificially created molecules, absent from the environment in which the species evolved, and immune responses are induced by these molecules as well. This is not due to indiscriminate binding of immune receptors to any type of molecule. We know that only 1 in $10^4 - 10^5$ lymphocytes in the body reacts to any given pathogen (Nossal, 1971). The second important constraint on the immune system is that it should not react to molecules normally present in the body. Such occurrences are rare, and constitute the domain of auto-immune disease.

The focus of my research has been to understand what and how the immune system can learn about its pathogenic environment. I investigated what the role of the immune receptor libraries might be, how they could maximize their responsivity to a very large pathogen universe, and how they would be affected by pathogen evolution. I then analyzed individual immune receptor sequences, looking for evidence that these sequences are evolvable under somatic hypermutation. I found that codon bias that enhances evolvability under somatic mutation is present in individual gene sequences from a variety of species. That is, while the mutation/selection process takes place during an immune response, the parts of the gene that encode the pathogen-binding region are more likely to undergo mutations which change the amino acid sequence. This is likely to increase the efficiency with which receptors with high specificity for the pathogen are generated. I went on to show that the observed efficiency of this process cannot be explained unless the lymphocytes go through a number of cycles of mutation-selection-expansion. Finally, I introduce methods for estimating mutation rates in a variety of biological systems. My goal was to be able to estimate the mutation rate of immune receptors during an immune response. However, the applicability of these methods for mutation rate estimation is considerable wider.

Infectious disease remains a considerable threat to human society. We witness the emergence of new infectious agents relatively often. The Influenza virus, which is responsible for the flu epidemics, is one of the better known of the evolving pathogens. Human immunodeficiency virus is a more recent acquaintance. What the universe of possible pathogens looks like is a mystery to us, and this situation is not likely to change any time soon. What we can do though, in the effort of

preventing infectious disease, is to understand what the immune receptors recognize, how immune memory develops, and how it is affected by pathogen evolution. The following chapters summarize my attempts in this direction.

1.2 Brief introduction to the immune system

1.2.1 Innate versus adaptive immunity

We are all well acquainted with the phenomenon of infectious disease. Starting at birth, we live in a sea of microorganisms that colonize our skin, nose, throat, etc. It is, however, quite rare that these microbes make their way into our blood stream and tissues. This is because we are endowed with multiple defense mechanisms that promptly detect and kill the intruders. The microorganisms that manage to cross physical barriers such as the skin, will face the agents of innate immunity, the phagocytic cells. *Phagocytosis*, the engulfment followed by destruction of microbes, seems to be the most basic defense mechanism, present in all animals (Beck and Habicht, 1996). The cells that perform this function are called *phagocytes*. They are not only the major players of innate immunity, but also the connection between innate and acquired (adaptive) immunity. All vertebrates, starting with jawed fish, are endowed with *adaptive immune systems*. The defining feature of an adaptive immune system is its specific, inducible response to pathogens. The response is called *specific* when we can demonstrate that the body fluids of the infected animal contain cells or soluble molecules that react to the infective microorganism, but not to others, and *inducible* when we can demonstrate that the anti-microbial activity of the serum increases in response to the infection. Thus, the major distinction between innate and acquired immunity is that of scope. Phagocytic cells are general-purpose effector cells that can kill a wide variety of microbes, whereas lymphocytes, the agents of acquired immunity, are specific to a single microbe, and probably its very close relatives. The discriminative capacity of lymphocytes is useful in distinguishing microbial components from the components of the body. It is also what makes it possible for mutating microbes to evade the immune response.

1.2.2 The development of an immune response

Let us follow the development of an immune response. Take, for example, a bacterium such as *Staphylococcus aureus*. For it to be able to infect a host, the integrity of the physical barrier (skin, mucosa) must be broken. The body has means to recognize such a breach. The actions that it then takes are twofold. It first attempts to close the breach, generally by building a temporary plug that

prevents leakage until the tissue is repaired. It then mobilizes various types of cells that can handle the intruding microorganism. Most infections are probably stopped at this level, by phagocytic cells that catch and destroy the bacteria as they come in. When their number is too large for the phagocytes to handle at the entry point, bacteria may spread, or even multiply in the tissue. From here they are carried by the lymph into the closest lymph node.

The lymph nodes have thick filters of phagocytic cells that pick up bacteria, but do not destroy them completely. Rather, they "process" bacterial proteins into short fragments, called peptides. These peptides are then loaded onto a special type of molecules which phagocytes produce, namely the major histocompatibility complex molecules (MHC). These complexes are then transported to the surface of the phagocytic cell, which now becomes an *antigen presenting cell*. The *antigen* is the complex of the MHC molecule and the peptide that it carries. This type of antigen can be recognized by the *T cells*, also known as *T lymphocytes*. T cells are of two major types: *helper* and *cytotoxic* T cells. Helper T cells start secreting molecules, *cytokines*, after being triggered by an antigen presenting cell. Cytokines regulate the functions of other lymphocytes, such as the B lymphocytes. Cytotoxic T cells are also triggered by antigen presenting cells, though through a different form of MHC. Once triggered, they may travel through the tissues. If they encounter a cell that has on its surface the complex of MHC and peptide for which the T cell is specific, that is, the one that activated the T cell, they induce that cell to commit suicide (in cellular terms this is called *apoptosis*). This mechanism is used in the defense against viruses. Viruses do not float around free in the body, they hide inside cells. Phagocytes do not generally detect them at this stage. But the host cell, that normally displays a sample of its protein content on the MHC molecules on its surface, will now also expose a sample of the viral proteins. These may be detected by the cytotoxic T cells, that in turn cause the infected cell to undergo apoptosis.

B lymphocytes, or *B cells*, also function as antigen presenting cells. In contrast with phagocytic cells, B cells pick up the antigen only in a very specific way, through their antigen receptor. The antigen receptor of B cells is also called *antibody* or *surface immunoglobulin*, largely as a result of the way researchers discovered these molecules. If a B cell encounters an antigen to which it can bind, it internalizes the complex of B cell receptor with the antigen, it processes it much the same as phagocytic cells process the antigen, and it presents MHC molecules loaded with peptides from this antigen on its surface. The antigen that B cells see is, however, in its native form, as it occurs for example on the surface of a bacterium. This is to be contrasted with the way T cells recognize the antigen, namely only in complex with MHC (*in the context of* MHC molecules). Once a B cell presents the antigen, it may interact with a T cell that sees the MHC-peptide complex on the surface of the B cell. A cross-talk between the two cells follows, with the effect of B cell activation.

Activated B cells undergo a number of divisions, and then can differentiate into plasma cells. These cells, instead of keeping their antigen receptor on the surface, start making copies of it and release them outside the cells. These free-floating antibodies can now be distributed throughout the body, detecting their specific antigen, and attaching themselves to its surface. Antibody-coated antigen is more readily accessible to phagocytes and other components of the innate immune system.

Subsequent encounters with an antigen trigger a faster, more efficient elimination of it, to the extent that the second infection may not even be clinically apparent. This is the essence of immune memory, although the mechanisms that underlie it are not completely understood. It is also what makes vaccination so efficient. Vaccination generally involves injecting a modified form of a bacterium, virus, or toxin, into the body. This will not cause the disease, as the microbe is inactivated. However, the modified form of the microbe will still bear antigenic molecules that induce an immune response. The memory cells that are generated in this process will be capable of eliminating a fully-functional microbe should it happen to infect the host.

1.2.3 Self-nonsel discrimination

The whole immune response is thus based on "recognizing" antigens, intruders, and so on. How is this recognition accomplished? At the site where microbes rush in, one can find dead cells, all kinds of soluble molecules that the body uses to fill the breach, other microbes, dead or alive etc. How do phagocytes know what to take up? A simple solution, which is to some extent what happens, is to take up just about anything. This may still require that the phagocyte itself be "activated". It is, in fact, known that the phagocytic capacity of these cells is stimulated by bacterial products, or by various molecules that are associated with cell damage. In this case, there is nothing that would prevent a phagocyte from presenting molecules that are produced by the host and just happen to be witnessing the scene of cellular destruction. If the phagocyte starts presenting peptides of these molecules, what prevents the immune system from becoming activated and destroying the host? To a large extent, this seems to be due to the deletion of self-specific T cells before they get the chance to move through the body. T cells are produced in a special lymphoid organ, the thymus. Once they acquire the antigen receptor on their surface, T cells are "tested" here against MHC-peptide complexes which reflect the proteins that the host produces. The peptides resulting from the fragmentation of the proteins produced in the host are called *self* peptides, and are to be distinguished from *foreign* or *non-self* peptides that derive from the proteins that are synthesized in the microorganism. T cells that bind tightly to self peptide-MHC complexes (called *autoreactive*) during this period of T cell development undergo apoptosis. To a certain extent, autoreactive B cells are also weeded out before they leave the bone marrow, where they are produced. So, even

though antigen presenting cells may present self-antigens, there are no lymphocytes to react to them, in particular, no T helper cells. Without T helper cells no immune response can proceed, and so *self-nonsel self discrimination* is realized. This is the view advocated, for example, in Langman and Cohn (1993). Recently, Matzinger (1994) challenged this view, arguing that immune responses directed against self structures (cells or molecules) occur for as long as there is damage, side by side with immune responses against the foreign microorganisms that caused the damage. To explain the self-limiting nature of the immune response, the argument is made that the immune system effectors induce cell death through apoptosis. The difference between apoptosis, the cellular equivalent of suicide, and other forms of death, is that the content of the cell is not released into the environment. Apoptotic cells are recognized by phagocytes, and inconspicuously removed. This way, the immune system is not further triggered. The effector cells eventually die, or return to their resting state, from which they can be restimulated only in the presence of damage.

1.2.4 The anticipatory capacity of the immune system

To be able to manifest their effector functions, all lymphocytes have to bind to antigen in a specific way, namely through their antigen receptor. The question is how the immune system manages to create receptors for antigens that it, and even the organism's ancestors, might never have encountered before.

As a first approximation, this is thought to be realized by the immune system making a large, diverse set of receptors that could potentially bind anything *but* the self molecules. Namely, through combinatorial assembly, a relatively small number of gene fragments, give rise to a large number of immune receptors. Before the cells start circulating in the body, their receptors are "tested" for the ability to bind self, and those that bind are deleted. It is only the remaining cells that move throughout the body, constituting the *naive repertoire*, the repertoire prior to any exposure to antigens. By construction, whatever these receptors bind is non-self. The hope is that when a harmful microorganism (*pathogen*) infects the host, there will be some cells of the naive repertoire that will interact with it. This mechanism is anticipatory in the sense that no prior knowledge of the pathogens needs to go in the construction of the immune receptors that can bind these pathogens. However, at any point in time, the immune system can only circulate a limited number of lymphocytes, and thereby a limited variety of receptors, through the body. It therefore seems crucial that the immune system make optimal use of its limited resources by somehow placing its receptors "strategically" in the space of possible receptors. If antigens are more likely to have certain shapes than others, one would expect the immune system to create receptors preferentially at locations in "shape space" where antigens are most likely to occur.

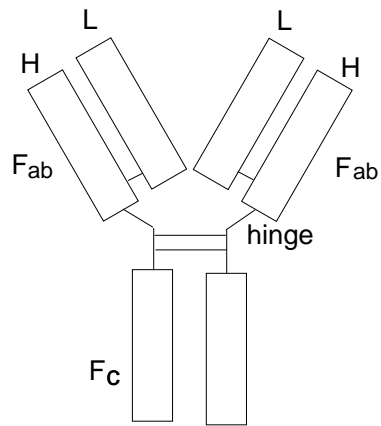

Figure 1.1: Schematic structure of the immunoglobulin molecule: two heavy chains (H) and two light chains (L) are bound to each other via disulfide bridges. The molecule is symmetrical, having two identical epitope-binding sites (Fab) and one site (Fc) that binds to receptors on effector cells, or interacts with the serum complex of complement proteins.

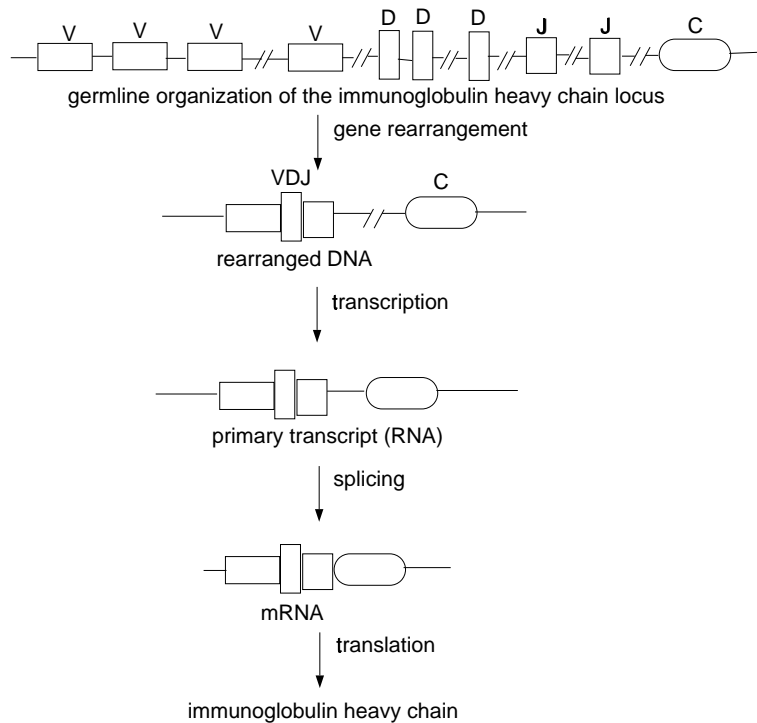

Figure 1.2: Processes leading to the synthesis of the immunoglobulin heavy chain.

The sequencing of the genes encoding the immune receptors revealed an astonishing organization, never before encountered in other genes. B cell receptors are tetramers and T cell receptors are dimers, made of four and two protein chains, respectively (Fig. 1.1). Each of these chains is the result of a combinatorial assembly process (Tonegawa, 1983) that concatenates two or three gene fragments. What makes immune receptors so special is that in the genome of each individual there are multiple genes, with somewhat different sequences, that encode one part of an immune receptor. That is, there are libraries of gene fragments (Seidman et al., 1978) (Fig. 1.2). In the case of the light chain, these fragments are denoted by V (variable) and J (joining). The heavy chain has an extra D (diversity) fragment, inserted between its own V and J fragments. A subscript is used to denote the homonymous fragments in the heavy and the light chains. In humans, for example, there are 39-45 different functional V_H genes, 23-30 different D genes, and 6 different J_H genes. Each chain receives, at its end, a constant fragment, C, responsible for its effector function. The recombination process leading to the synthesis of the immunoglobulin heavy chain is shown in Fig. 1.2. When the V(D)J fragments are assembled into the rearranged gene, their ends may be trimmed, and an enzyme, terminal deoxynucleotidyl transferase (TdT), adds at the junction nucleotides that were not encoded in the genome (Gilfillan et al., 1993). Finally, during an immune response, B cells that have been selected for interaction with the pathogen undergo mutation of the rearranged immunoglobulin gene (Weigert et al., 1970). Within a special environment, the germinal centers of the lymphoid organs, this process of *somatic hypermutation* is coupled to selection for efficient interaction with the pathogen, and leads to what is called *affinity maturation*. The memory population of B cells coming out of the germinal centers has a higher average affinity of immune receptors and is generally more efficient in clearing the pathogen at subsequent encounters. Yet another diversity-generating mechanism operates on rearranged V(D)J genes in species such as chicken and rabbit. Chickens have only one functional V gene. Rabbits have more than one, but one of these genes is responsible for 80% of the rearrangements. After the whole receptor gene has been assembled through rearrangement, another, yet uncharacterized, mechanism replaces part of the gene with a copy of a gene fragment coming from another V gene or pseudogene in the genome. This process is called *gene conversion* (Fig. 1.3).

Thus, there are multiple sources of diversity in B cell receptors:

- Whereas most other proteins in the body are encoded by one gene, or multiple identical copies of a gene, each of the gene fragments that is used in assembling immune receptor genes has multiple, non-identical variants in the genome. Each B cell in turn uses exclusively one member of this set for its receptor.
- Each of the B cell receptor chains is randomly assembled from 2 (the light chain) or 3 (the

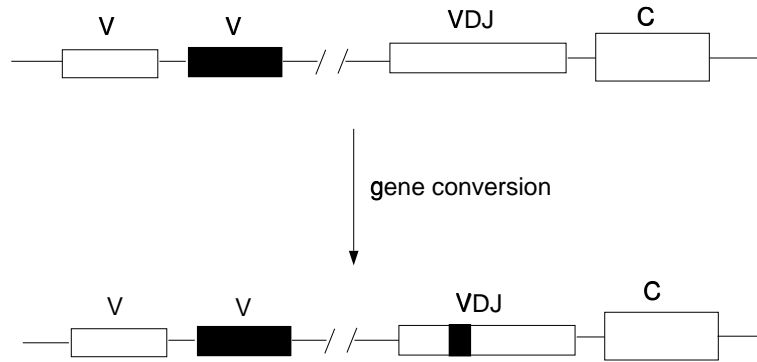

Figure 1.3: Schematic representation of the gene conversion: an already rearranged VDJ gene replaces part of its sequence with a copy of a fragment coming from another V gene. The latter gene remains unchanged.

heavy chain) gene fragments. Once this *rearrangement* occurs, the B cell generally does not undergo subsequent rearrangements.

- During the rearrangement process, the ends of the gene fragments undergo processing, some of the nucleotides being lost, and others, for which no genetic information was present, may be added.
- During the germinal center reaction, individual B cells may accumulate mutations in the gene encoding their immune receptor. These mutations only affect individual B cells, and are not recorded in the gene libraries that the organism transmits to its offspring. Whereas the organization of the immunoglobulin gene libraries and their rearrangement mechanism evolve on the level of the whole organism, the germinal center reaction constitutes an evolutionary process on the level of individual B cells.

Due to molecular biology techniques, we now know what mechanisms are responsible for creating diverse immune receptors. Diversity, however, cannot be the goal. After all, assembling an immune receptor in a non-template manner, just like TdT does with the junctional regions, would be a better way to create diverse receptors. The genes encoding immune receptors are carrying some information, and what that information might be is the question that stirred my interest.

1.2.5 Structural components of the immune receptors

I will briefly describe the structural elements of an immune receptor, as I will be focusing on their properties later. When one aligns a number of immunoglobulin heavy chains coming from different B cells, it becomes apparent that some amino acid positions are more similar among the sequences

Schematic view of the antigen-binding part of an antibody

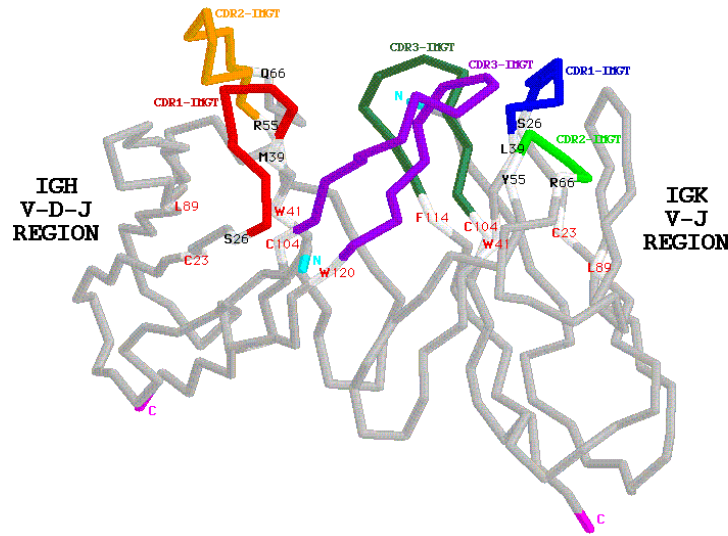

Figure 1.4: Schematic view of the variable part of an antibody molecule (IMGT, the international ImMunoGeneTics database <http://imgt.cnusc.fr>: 8104). The CDRs are shown in color, the FRs in between them are shown in gray.

in the set than others (Wu and Kabat, 1970). In fact, stretches of relatively conserved residues alternate with stretches of relatively high diversity. Analysis of the crystal structure of antigen-antibody complexes revealed that the positions of high variability are involved in antigen binding (Amit et al., 1986), and thus they are called *complementarity determining regions* (CDR). These regions also seem to be more susceptible to somatic hypermutation (Motoyama et al., 1991; Varade et al., 1993; Wagner et al., 1995; Kepler, 1997; Dörner et al., 1998; Cowell et al., 1998). The more conserved regions are packed inside the molecule or are involved in the pairing of the heavy and light chains (Foote and Winter, 1992). They are called *framework regions* (FR). The V gene fragment is responsible for encoding FR1, CDR1, FR2, CDR2, and part of the CDR3. The J gene fragment encodes part of CDR3 and FR4. In heavy chains, the D gene fragment also contributes to CDR3. Fig. 1.4 shows the variable part of an antibody molecule, with the CDRs that are contributed to the binding site by both heavy and light chains. The C fragment, that encodes the constant part of the immune receptor and is responsible for the effector functions is shown in Fig. 1.1.

A comparative analysis of the immune repertoire in various species, and in various developmental stages of an organism, reveals that there is a lot of variability in the way the repertoire is created. The diversity of V region genes that are present in the germline can vary considerably. In sharks, all V genes are more than 90% homologous, whereas in mice and humans the pairwise

homology between these genes can be as low as 70%. In neonates, the combinatorial and junctional diversity seem to be circumvented (Feeney, 1992). Preferential V-D and D-J joining could reduce the repertoire to a relatively small set of germline-encoded antibodies. In sharks, we encounter the extreme of this spectrum (Hinds-Frey et al., 1993). A large fraction of their antibody genes are already joined in germline, with no possibility of combinatorial diversification. The light chain-heavy chain pairing is abolished in camel IgM homodimers. The absence of TdT in genetically manipulated mice does not visibly affect their survival chances (Gilfillan et al., 1993). All this data argues that combinatorial diversity might not be indispensable for survival. Two features, however, seem to characterize all the immune systems encountered in nature: An organism has multiple genes that encode immune receptors; A secondary diversification mechanism is always found, and generally that mechanism is somatic hypermutation. In the following chapters, I will present a number of models that I used to explore the contribution of the germline diversity and somatic hypermutation to the immune repertoire. I will argue that the naive repertoire is likely to realize a coarse-graining of the pathogen space, with somatic hypermutation being required for improving the affinity/specificity of the antigen-selected antibodies. I will also analyze the factors that contribute to the efficiency of somatic hypermutation.

Chapter 2

How much can germline diversity do?

An immune receptor gene is assembled from a number of gene fragments. Each of the fragments comes from a gene library, and only one member of each of the gene libraries is used for a given immune receptor. The V fragment is the largest of the two (or three, in the case of the antibody heavy chain and T cell receptor β chain), with a length of approximately 100 amino acids. What shapes the evolution of the immune receptor libraries is largely unknown. Given that epidemics have been an important selection pressure in the evolution of human populations we expect that these gene libraries bear the traces of the antigenic exposures of the species. On the other hand, immune responses to artificially-produced molecules have been induced in mice, suggesting that the immune system is able to recognize more than the antigens that the species encountered in its evolution. These observations lead to the idea that the immune system creates its receptors so as to be able to recognize as many molecular shapes as possible. Was the immune system evolved in such a way, or does it only focus on the molecular shapes that are most detrimental to the survival chance of the organism?

In the following section I will explore the scaling between the fitness of the organism—defined as its probability to survive in a pathogenic environment—and the size of its antibody repertoire. I will argue that the functional form of this dependency suggests that the role of germline diversity must be to broadly map the regions of the pathogen space that are relevant for the survival of the organism. Moreover, I will argue that biases in the pathogen exposure of the individuals, such as sampling the pathogen universe, would preclude the evolution of germline-encoded antibodies that optimally cover the complete space of molecular shapes. Thus, contrary to what is commonly

believed, I argue that the immune system does not handle as many molecular shapes as possible. It rather focusses on those that have been important for the survival of the species. Responses to artificially constructed molecules are possible because these molecules are sufficiently similar to epitopes that are encountered on pathogens.

2.1 Shape space coverage with distance-dependent matching

The concept of a shape space was introduced by Perelson and Oster (1979). Since then, it has been used in numerous theoretical studies of the immune system, of which I will only mention a few (Perelson, 1989; Segel and Perelson, 1989; De Boer et al., 1992; Detours et al., 1994). In this framework, it is postulated that molecular interactions can be understood in terms of the "shape" of the molecules. The crucial assumption of this model is that the "shape" of a molecule can be represented by a vector of discrete values, from a finite, generally small, alphabet. Rules are specified for determining the "affinity" between two such "shapes". There have been attempts to relate this model to measurements that can be obtained in biological systems As (B-Rao and Stewart, 1996; Smith et al., 1997). I therefore decided to use this conceptualization for my study on the evolution of antibody gene libraries.

It is generally assumed that the number of pathogens in the environment of a species is very large. Indeed, if this number was small, the immune system would be able to distribute its resources, such as antibody molecules, among these pathogens. Each of the pathogens would raise an effective immune response. This is clearly not what we observe in reality. Therefore, I will assume that the pathogen universe is large. One has to keep in mind, though, that the failure of the immune system to cope with all the pathogenic challenges that it encounters may be due to other factors. Pathogen evolution sets a moving target for the immune system. As I will show in the following section, the rate at which the antibody library adapts to an evolving pathogenic environment might be too slow for the immune system to ever pin down even a small pathogen set.

Let us assume that the number of antibody shapes encoded in the genome is considerably smaller than the number of antigen shapes that the organism encounters during its life time. To understand the role of the antibody gene libraries in the generation of the immune repertoire, I will address the following questions:

- How does the survival probability of the organism scale with the size of its immune receptor repertoire?
- What structure do antibody libraries evolve in different types of pathogenic environments?

- Can an antibody repertoire that has been selected for interaction with pathogens perform equally well in the interaction with non-pathogenic antigens?

2.1.1 Model

To address these questions, I implemented an evolutionary algorithm, similar to the one introduced by Hightower (1996). The basic components of the model are the following:

- A population of individuals, each having a gene library of A genes. Each gene is represented by a bit string of length L . From this library, I assume that A antibodies are made, that is, all genes are expressed, and that all these antibodies are available for binding any of the pathogens. I do not distinguish between the genotype (antibody gene) and the phenotype (antibody molecule). One could, alternatively, view the libraries as representing the possible set of antibodies that an organism can produce. The genetic operators, to be discussed below, such as mutation and recombination on these libraries would then have to be thought to represent phenotypic changes to the antibody repertoire as a result of implicit genetic operations on the level of the genes. Also, I will not include the rearrangement process in the model. This choice is meant mainly to keep the model simple. Note, immune receptor rearrangement does not play a major role in generating diversity in all species, and thus the simple model that I propose has direct significance for these situations.
- Pathogens are also represented as bit strings of length L .
- The essence of the complicated antibody-pathogen interaction in the real world, that I want to capture in this model, is that for each pathogen in the environment, the host can raise at least one antibody that can recognize the pathogen. The level of recognition may or may not be protective for the individual. As suggested recently (Dal Porto et al., 1998), I will not require a certain affinity threshold for protection. I will simply assume that the lower the affinity, the lower the survival chances when the host is presented with that given pathogen. Thus, to each individual library, \mathcal{A} , I assign a score in matching a pathogen p , defined as

$$\phi(p) = \frac{1}{L}(L - \min_{a \in \mathcal{A}} [h(a, p)])$$

where $h(a, p)$ is the Hamming distance between antibody a and pathogen p . In other words, for each pathogen, we find the antibody with the minimal Hamming distance to the pathogen. The score is a number between 0 and 1, being maximal for a perfect match, at Hamming distance 0, and minimal for the case of complementary bit strings. Note that I use identical

lengths for the antibody and the pathogen strings and that the bit strings are aligned prior to calculating the Hamming distance.

- In Hightower (1996), the fitness f of an individual was defined as the average score $\langle\phi\rangle$ with respect to all pathogens that it encountered. I will use the same fitness function here. I believe that this choice can be most generally justified in terms of the survival probabilities of an individual with respect to the pathogen challenges it encounters. All these challenges have to be met successfully if the organism is to survive. Let us assume that the probability s_p of surviving the attack of pathogen p grows exponentially with the score $\phi(p)$. That is, for each additional matching bit between the best antibody and the pathogen, the probability s_p that the organism survives goes up by a constant factor, $k^{\frac{1}{L}}$. Thus,

$$s_p \propto k^{\phi(p)}.$$

The probability of surviving *all* pathogen attacks is given by the product of the survival probabilities s_p for all pathogens p . Therefore, the total survival probability s is given by

$$s \propto k^{P\langle\phi\rangle}$$

where P is the number of pathogens, and $\langle\phi\rangle$ is the score of the library averaged over all pathogens. Thus, we find that the survival probability s is a monotonically increasing function of the average score $\langle\phi\rangle$. For the selection scheme (described below) that I used, only the relative ranking of the fitnesses of different libraries is important. Therefore, under the assumption that the fitness of an individual depends only on its survival probability s , we can identify the fitness with the average score $\langle\phi\rangle$. Formally, if we denote the pathogen set by \mathcal{P} , the fitness f of an individual is given by

$$f = \frac{1}{P} \sum_{p \in \mathcal{P}} \phi(p) \equiv \langle\phi\rangle.$$

- I will evolve the antibody libraries on the following pathogen sets:
 - The complete set of 2^L pathogens of length L .
 - Random subsets \mathcal{P} of the complete pathogen set of size 2^L . These sets are constructed by sampling P pathogens, with replacement, from the complete pathogen set.
 - Pathogen sets that evolve independently of the hosts.

- The evolutionary algorithm that I used has the following structure. The initial population consists of $M = 50$ random libraries, of identical size, A . This population size is sufficiently large to allow convergence to relatively high fitness solutions, given the mutation rate of 0.002 per bit that I used in evolving the libraries. Each individual, then, consists of a single library. I use rank selection as follows: If r is the rank of the fitness of an individual in the population, the chance of that individual being selected as a parent is, on average, $w_r = \frac{2(M-r)}{M(M-1)}$. To create one library of the new generation, I select, with replacement, two libraries of the old population, then generate two new libraries by crossing over the two chosen libraries. The number of crossover points n is chosen from a binomial distribution with mean $0.01A$. This crossover scheme is more realistic for our purpose of modeling the evolution of gene libraries than other schemes that are described in the evolutionary algorithms literature (Mitchell, 1996). The crossover points are chosen at the boundary between antibodies, so individual antibodies are not disrupted by crossover. I then choose one of the new crossover products, mutate it, and add it to the new population. 1000 generations of the genetic algorithm constitute a run. At the end of the run, I take the library with the highest fitness in the population, and use it to infer the scaling relation, as well as for analyzing the properties of antibodies that were evolved.

A note about the random number streams. The basic function of the random number stream returns a random deviate from a uniform distribution on the interval $[0,1)$. The algorithm is given in Knuth (1973), and the implementation that I used was written by Terry Jones. This function can be used to generate random deviates of the uniform density function over any interval between 0 and any positive value.

2.1.2 Lower bound on the evolved fitness

The performance of a random library should give us a lower bound on the fitness of *evolved libraries*, given that I start the simulation with random antibody libraries. I therefore derived the expected fitness of a random library on the complete pathogen set of size 2^L . Let $\phi(p_i)$ be the score of an individual with respect to pathogen p_i and m the number of matching bit positions between a pathogen and an antibody. For a pathogen binding to a single random antibody, the probability that there are x or fewer matching bits, $Pr\{m \leq x\}$, is given by the value of the cumulative binomial at x . If we have A random antibodies, the probability that all of them have x or fewer matching bit positions with the pathogen is $[Pr\{m \leq x\}]^A$. Then the probability that the score $\phi(p_i)$ of the individual with respect to pathogen p_i is x/L , is given by the probability that at least one antibody

has x matching sites with the pathogen but none has more than x , i.e.,

$$Pr\{\phi(p_i) = x\} = [Pr\{m \leq x\}]^A - [Pr\{m \leq x - 1\}]^A.$$

The expected score of a random library of A antibodies with a random pathogen p_i is then given by

$$E[\phi(p_i)] = \frac{1}{L} \sum_{x=0}^L x Pr\{\phi(p_i) = x\}.$$

The expected score of a random library on a randomly chosen pathogen p_i also represents the expected score of a random library over the complete set of 2^L pathogens. We then denote the expected fitness of a random library over the complete pathogen set by f_r ,

$$f_r = E[\phi(p)] = \frac{1}{L} \sum_{x=0}^L x [Pr\{m \leq x\}]^A - [Pr\{m \leq x - 1\}]^A. \quad (2.1)$$

The above equation for f_r gives a lower bound on the fitness of the evolved libraries as a function of L and A .

2.1.3 Upper bound on the evolved fitness

I also calculate an upper bound for the fitness of the evolved libraries by using a theorem from the theory of error-correcting codes (MacWilliams and Sloane, 1986). Assume that we distribute the A antibodies over the space of 2^L pathogen bit strings in such a way that each antibody a_i covers a set S_i of volume V_i , corresponding to the number of pathogens up to Hamming distance d from antibody a_i . Assume that all sets S_i are disjoint and of equal size. In the best situation, there exists a Hamming distance d such that the sets S_i together exactly cover the space of 2^L pathogens. Since

$$V_i = \sum_{h=0}^d \binom{L}{h},$$

this yields the inequality

$$A \sum_{h=0}^d \binom{L}{h} \leq 2^L, \quad (2.2)$$

In the theory of error-correcting codes, this inequality is known as the sphere-packing or Hamming bound. The library is "perfect" if equality holds. The fitness f_u of such a perfect library is given by

$$f_u = 1 - \frac{\sum_{i=0}^d i \binom{L}{i}}{\sum_{i=0}^d L \binom{L}{i}}.$$

However, it may be that a "perfect" library cannot be constructed. That is, there is no value of d for which the A disjoint Hamming distance d -balls around the antibodies cover the space completely. In this situation, we first determine the maximum value of d for which the inequality 2.2 still holds.

Each antibody will cover a ball of pathogens around itself, up to Hamming distance d . The rest of the pathogen strings, that do not fall in any of the A Hamming distance d -balls around the antibodies, will be at Hamming distance $d + 1$ from at least one of the antibodies. Thus, given this value d , the upper bound on the fitness will be given by

$$f_u = \frac{A \sum_{i=0}^d (L-i) \binom{L}{i} + \left(2^L - A \sum_{i=0}^d \binom{L}{i}\right) (L - (d+1))}{L2^L}.$$

2.1.4 The fitness of evolved libraries

How does the fitness of the evolved libraries compare to the bounds that we calculated?

I used a string length $L = 8$ bits to explore the scaling relation between the maximum fitness evolved by a library and the number of antibodies, A , in the library. The fitness of the libraries was computed over the complete set of 2^L pathogens at each time step. For each library size, I averaged the best fitness values obtained in 10 independent runs.

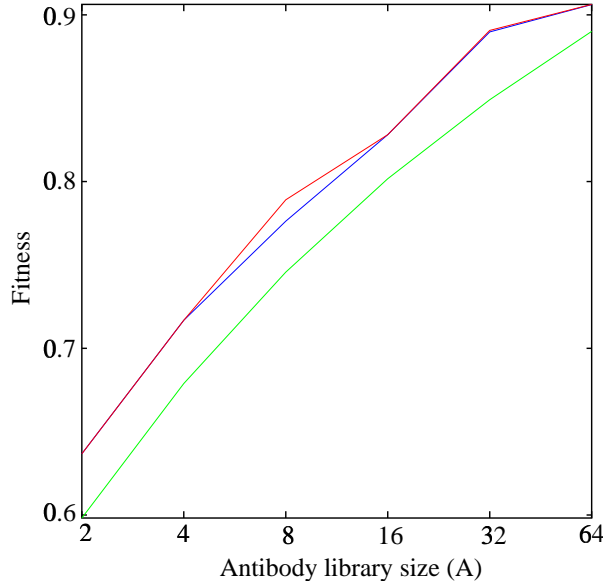

Figure 2.1: Scaling of the fitness with respect to the antibody set size A . Upper, red, curve is given by the sphere-packing bound. Middle, blue, curve gives the fitness of the evolved libraries. The best fitness values evolved in 10 independent runs were average for each data point. String length is $L = 8$, library size $A = 2, 4, 8, 16, 32, 64$. Lower, green, curve represents the fitness of random libraries.

Fig. 2.1 shows the fitness of the best evolved library \bar{f} , as well as the upper (f_u) and lower (f_r) bounds that I calculated. It is clear that the fitness, \bar{f} increases slower than logarithmically as a function of the library size. In fact, we may infer the following approximate relation:

$$f = c \log^\alpha(A).$$

\bar{f} , f_u and f_r obey roughly the same scaling relation, with $\alpha \approx 0.2$. The c values however differ between the different curves, and the basis for this difference is explored below. The evolved libraries do not always reach the fitness f_u as given by the "perfect" libraries, but they generally come very close to this value. The similar scaling relation for evolved libraries, as well as for random libraries and "perfect" libraries suggests that the scaling relation is mostly a result of the geometry of the bit-string space and the additive nature of the matching rule.

Thus to obtain an increase of δf in fitness one would have to multiply the size of the libraries by larger and larger factors. The selection pressure for increasing the size of the germline-encoded repertoire is thus expected to be progressively lower. A similar dependency was suggested, on experimental grounds, and within a somewhat different model, by Minar (1994).

2.1.5 The strategy of evolved libraries

What strategy do the relatively small antibody libraries evolve for matching the much larger set of pathogens? If the pathogen set was small, we would expect that the antibodies evolve to track the pathogens perfectly. Thus, in the structure of the antibody library will directly reflect the structure of the pathogen set. What we do not know is what strategies these libraries develop when confronted with a pathogen set much larger than the size of the library, or with a very dynamical pathogen set. In the first scenario, it would be impossible to track pathogens individually. In the second scenario, the ability to track pathogens individually probably depends on the relative rate of evolution of the pathogens on one hand, and the antibody library, on the other. To investigate the type of library structure that evolves in these cases, I performed the following evolutionary algorithm experiments.

The set of all 2^L bit strings will be denoted as the pathogen universe. A subset of it will be used for training the antibody libraries. I call this the training set. For a length $L = 16$ of antibody and pathogen bit strings, I generated, with replacement, training sets of size 2, 4, 8, 16, 32, 64, 128, 256, 512, 1024, 4096, and 16384. Using these sets, I then evolved gene libraries of size $A = 8$, as previously described. I further investigated two types of pathogen dynamics. These are meant to correspond to:

1. pathogenic environments that change from one generation of hosts to another, and
2. individual pathogens slowly drifting in the molecular shape space.

I simulated the first type of dynamics by replacing 8^{th} of the training set at generation of hosts. The second type of dynamics I implemented by mutating each pathogen in the training set with 0.1 probability per pathogen per generation of hosts. The exact values of these parameters are arbitrary. The intent, however, is not to give quantitative predictions, but to understand the qualitative

behavior of the libraries under the two types of pathogen dynamics.

To assess library structure, I use an observation of Hightower (1996). Investigating the type of library that evolves when the pathogen set is very large, the author conjectured that the antibodies tend to maximize the average Hamming distance to other antibodies in the library. I can, in fact determine what this distance will be, and then ask whether this strategy is employed both by libraries that evolve in large, static pathogenic environments, as well as in small, rapidly changing pathogenic environments.

The average pairwise Hamming distance within a library is given by

$$\langle h \rangle = \frac{2}{A(A-1)} \sum_{i=1}^A \sum_{j=i+1}^A h(a_i, a_j)$$

where A is the number of antibodies in the library, and a_i and a_j are individual antibodies. The Hamming distance between two antibodies, $h(a_i, a_j)$ is given by:

$$h(a_i, a_j) = \sum_{k=1}^L \delta(a_i^k, a_j^k)$$

where a_i^k and a_j^k denotes the k^{th} bit position of the two strings, and

$$\delta(a_i^k, a_j^k) = \begin{cases} 1 & \text{if } a_i^k \neq a_j^k \\ 0 & \text{otherwise} \end{cases}$$

We may now switch the order of summations to obtain:

$$\langle h \rangle = \frac{2}{A(A-1)} \sum_{k=1}^L \sum_{i=1}^A \sum_{j=i+1}^A \delta(a_i^k, a_j^k)$$

and since the bits are independent, maximizing this quantity means maximizing the pairwise Hamming distance at each bit position. If for bit position k we denote by n_0 the frequency of 0's in the antibody population at that position, then the pairwise Hamming distance at that position is $n_0(A-n_0)$. This quantity is maximal for $n_0 = A/2$. Substituting into the above equation, we obtain the maximal average Hamming distance in the population:

$$\langle h \rangle = \frac{LA}{2(A-1)}.$$

For libraries of 8 antibodies of length 16, the average pairwise Hamming distance between the antibodies in the library would have to be 9.1429. Let us now return to the two types of pathogenic environments: a static, large, training set (of size $P = 2^{12}$), and a small training set (size $P = 8$), with one pathogen being replaced by a random other at each generation of hosts. All 5 libraries evolved on the large, static training set had an average pairwise Hamming distance of 9, whereas

in 9 out of 10 libraries evolved with dynamic training set, the average pairwise Hamming distance in the library was 8 (in the 1 other case it was 7). To determine the significance of this difference, I constructed 10^6 random libraries of 8 antibodies, and calculated the average pairwise Hamming distance in each of these libraries. I used these values to construct the distribution of average pairwise Hamming distance for random libraries. It is not surprising that the libraries that were evolved on small, dynamic, training set cannot be distinguished (using the average pairwise Hamming distance statistic) from random libraries. On the other hand, the libraries evolved on large, static training sets have significantly higher average pairwise Hamming distance than random libraries of the same size (p -value = 1.1×10^{-5}). I thus conclude that a small, dynamic training set does not allow the antibodies to distribute themselves in space such as to optimally cover the pathogen universe.

Though having maximal average Hamming distance between the genes in the library seems to be a necessary condition for maximal fitness, it is not sufficient. Clearly, a library of size $A = 8$ composed of four copies of a string and four copies of its complement has maximal average pairwise Hamming distance, but it is far from being optimal. It is unclear what other condition needs to be fulfilled for a library to achieve maximal fitness.

Let us return now to the question of whether the libraries learn to recognize the pathogens on which they have been trained, or they evolve such as to maximize recognition of a random molecular shape. I used the libraries that I evolved in the experiments described above to determine their expected fitness to a random shape in the universe. That is, I determined the average fitness of the libraries on all pathogen bit strings of length $L = 16$.

Fig. 2.2 shows the results. For static training sets (upper curve) 100 runs were used for training set sizes 8, 16, 32, 64; 50 runs for training set sizes 128 and 256; 25 runs for training set size 512; 10 runs for training set size 1024, and 5 runs for training set size 4096, and 16384. For changing training set, 10 runs were performed for each training set size, with the exception of the training set size of 4096, for which 6 runs were used. As the figure shows, the most important determinant of the fitness relative to a random pathogen is the fraction of the pathogen universe that a host encounters in one generation. If this fraction is large, fitness of evolved library is high, independent of the pathogen dynamics. This is not surprising. In the limit of the training set being the pathogen universe itself, these scenarios are indistinguishable. Libraries evolved on small, but variable training sets have lower performance on a random pathogen than libraries that evolved on large and static training sets (or large, but dynamic pathogen sets). This shows that the small, dynamic, pathogenic environments do not allow optimal placement of antibodies in the space of molecular shapes. On the other hand, the libraries that evolve in environments with few pathogens have a higher expected performance on random pathogens if the environment in which the libraries evolve is dynamic. The

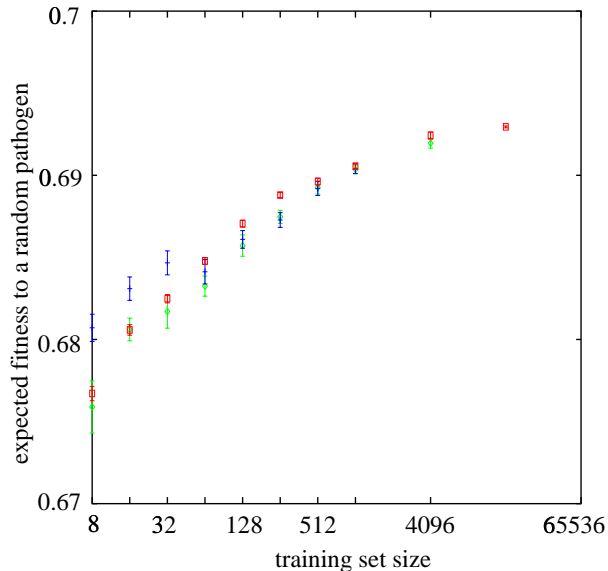

Figure 2.2: Expected fitness of evolved libraries with respect to a random pathogen, as a function of the training set size. The libraries that were evaluated are the ones evolved on static training set (red), slowly changing training set (green), rapidly changing training set (blue).

reason is that the static environment supports the evolution of very specialized libraries, while the dynamic environment essentially maintains random antibody libraries. A somewhat similar idea was reported by Hightower (1996), who found that stochastic antibody expression induces libraries that are more robust in handling a random pathogen.

Fig. 2.3 summarized these results from a somewhat different perspective. Namely, how different is the fitness of an evolved library with respect to the training set, as opposed to a random subset of the same size taken from the pathogen universe. Consider \mathcal{A} , an evolved library of fitness f relative to the training set. Its fitness relative to a random pathogen in the universe can be calculated by averaging the fitness of \mathcal{A} with respect to all pathogens in the universe. Let us denote this fitness by f_0 . If we take a random subset of P pathogens from the pathogen universe, the fitness of \mathcal{A} relative to this subset is still f_0 . The variance in fitness relative to a random subset of P pathogens is a fraction $1/P$ of the variance relative to a random pathogen (σ^2). I chose the value of the z-statistic as the indicator for significantly higher performance on the training set.

$$Z = \frac{f - f_0}{\sigma/\sqrt{P}}.$$

The results, for library size $A = 8$, and string length $L = 16$, are plotted in Fig. 2.3. The upper curve corresponds to static training sets. The middle curve corresponds to training sets that change slowly through mutation of individual pathogens. Finally, the lower curve corresponds to the situation when

pathogens in the training set are replaced by random others from one host generation to the next.

As we expect, when the training set is large, the libraries are confronted with essentially the complete pathogen universe at every generation. The three scenarios for pathogen dynamics are indistinguishable. The curves converge to a regime of training set-independence, essentially because any pathogen set of very large size will be a permutation of the training set, and the fitness does not depend on the order in which pathogens are presented.

The regime of training set-independent fitness is reached faster when pathogens change slowly (mutation rate 0.1 per pathogen per generation of hosts). The libraries optimize their coverage of the pathogen universe, as judged by the average pairwise Hamming distance between the antibodies in the library. In all of the 6 independent runs with training set of size 4096, the average pairwise Hamming distance in the evolved library was higher than 9. As I showed before this value is significantly higher than one would expect for a random library.

Training-set independence of the fitness of the evolved library characterizes all libraries evolved in highly dynamic pathogenic environments. However, as I showed before, small and dynamic training sets promote libraries of essentially random antibodies. This makes their fitness on random pathogen sets indistinguishable from the fitness on the training set. However, given that these libraries do not specialize, their fitness on a random pathogen is higher than if the libraries were evolved in a static, small, pathogenic environment.

I briefly return to the question of whether the immune system might construct its receptors such as to recognize as many molecular shapes as possible. This hypothesis stemmed from the observation that challenging the immune system with artificially constructed molecules gives rise to immune responses. How would we explain these findings under the hypothesis that the immune system is selected by pathogens that affect the survival of individuals?

There are two issues that merit discussion. The first is whether the immune system optimizes its recognition of random pathogens, the other is whether it optimizes its recognition of the molecular shape space. The answer to the first question is that, if pathogens are independent from one another, the immune system needs to be presented with a large fraction of the pathogen universe at each generation to be able to optimize its recognition of random pathogens. This fraction is somewhat lower if pathogens also evolve from one generation of hosts to the next (the condition that the pathogen set is considerably larger than the antibody libraries still has to be maintained).

Regarding the recognition of the molecular shape space, we would probably need to do the following experiment. Assuming that the pathogen universe is a fraction p of the molecular shape space, we may distribute the pathogens in the space in different ways. The two extremes are:

- We choose a random point in the space, and then progressively add its neighbors, in increasing

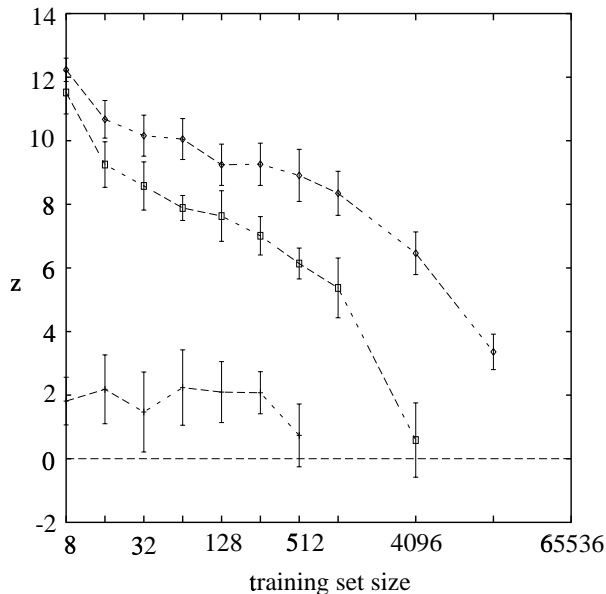

Figure 2.3: Dependence of the z-statistic on the training set size P . The size of the antibody library was kept constant, $A = 8$ genes. Length of antibody and pathogen strings is $L = 16$ bits. The three data sets are, from top to bottom, static pathogen set, slowly mutating pathogen set, rapidly changing pathogen set. The number of independent runs for each pathogen set size is given in the text.

order of the Hamming distance, until we reach a pathogen set size of $p * 2^L$.

- We construct the pathogen set by choosing, with probability p , each of the 2^L points of the molecular space.

We expect that the antibodies that will evolve in these two situations would have very different performance on a random molecular shape. Namely, the recognition of a random molecular shape will be higher if the pathogens are scattered through the space.

2.2 Shape space coverage with other matching rules

Although the concept of a shape space has spun numerous studies on the behavior and evolution of the immune system, it is not clear that intermolecular interactions are well described in this manner. In fact, a survey of the literature also reveals discussions of the relevance of the shape-space model, at least in idiotypic interactions (Carneiro and Stewart, 1994). I therefore decided to investigate the impact of another fitness function on the basic scaling result that I obtained above. The fitness function that stems from the shape-space metaphor is highly structured, the fitness of an individual being given by the antibody with the smallest Hamming distance from the pathogen. We would like

to know what happens if the fitness landscape has a completely different structure. The option I explore is based on the idea of a random energy model, introduced by Derrida (1984), in the context of spin-glasses.

If we view the antigen-antibody interaction from a biochemical standpoint, the strength of the bond is given by the difference of the free energies of the complex, and of the two molecules in their unbound state. A realistic representation of the energy landscape as a function of the sequence of the molecules is clearly impossible at this point. Therefore I use the following abstraction. I assume that each molecule has an "energy", which is a random deviate from a Gaussian distribution. The antigen-antibody complex also has an energy corresponding to it, which is a random deviate of a Gaussian distribution. The difference between the energy of the complex and the energy of unbound molecules gives the strength of the bond between them. I perform this calculation for all antibodies that the individual can make, and I take the maximum bond strength between an antibody and the pathogen to be the fitness with respect to that pathogen. I then use the evolutionary algorithm that I described in section 2.1.1 to evolve libraries of different sizes on a complete pathogen set of size $P = 2^9 = 512$. As the bit-strings that I used have length $L = 9$, the 7 high order bits are set to 0. The best library evolved in 1000 steps is used to infer the scaling relation between fitness and antibody library size.

The energy of antigens and antibodies is drawn from a Gaussian distribution with mean 50, and variance 2.5, whereas the energy of the complex was chosen from a Gaussian distribution with mean 100 and variance 10. Although the exact choice of the mean and variance of the energy of an individual molecule is arbitrary, there clearly is a scaling of the energy of a molecule with its size, so we expect that by doubling the size of the molecule we roughly double the energy associated with it. To determine the energy of each molecule, I seed the random number generator with the numerical representation of the bit string representing that molecule, and then calculate a pseudo-random Gaussian deviate according to the algorithm given in Press et al. (1988). I assign such an energy to both antigen and antibody. To obtain the antigen-antibody complex, I take the XOR between the bit strings representing the antigen and the antibody. I use the numerical representation of this bit string to calculate an energy, as described above. The bond strength, given by the difference in energy between the complex and the unbound molecules, will be distributed as a Gaussian with mean 0 and variance 15.

One might argue that the landscape thus constructed does not have any obvious structure for the evolutionary algorithm to work with, given that the energies assigned to closely related genotypes are random deviates from the Gaussian distribution. The landscape does, however, have some structure, as the antibodies with high energy have a better chance of lowering this energy by

binding to pathogens. These are, in fact, the antibodies that the evolutionary algorithm discovers.

In the previous section I showed that, for the shape space model, the scaling relation between fitness and library size in the case of evolved libraries is essentially a shifted variant of the relation that we obtain for a random library of identical size. I will show that this is also the case for the energy model that I just described.

2.2.1 Lower bound on the fitness

Let us first determine the fitness of a random library as a function of the library size. I will write the derivation in the most general sense, in terms of the density distribution of the bond strength, $g(x)$, and its corresponding cumulative density function, $G(x)$, and I will apply it to the particular Gaussian distribution of bond strengths that I mentioned above.

For every pathogen, the fitness is given by the maximum of A random variables drawn from the distribution G , A being the size of the antibody library. The probability that the bond strength between a random pathogen and all of the antibodies in the library is less than or equal to a value, x , is $G(x)^A$, and then the derivative of this, giving the probability density of fitness x , is

$$g_A(x) = \frac{d}{dx} [(G(x))^A] = A \times g(x)(G(x))^{A-1}. \quad (2.3)$$

Now the expected fitness of a random library of A antibodies on the complete pathogen space, given the probability density function of the fitness, $g_A(x)$, is

$$f_g(A) = \int_0^\infty x g_A(x) dx = \int_0^\infty x \frac{d}{dx} [G_A(x)] dx. \quad (2.4)$$

Let $y = G_A(x)$, taking values between 0 and 1. Then $\frac{d}{dx} [G_A(x)] = dy$ and Eq. 2.4 can be rewritten in terms of y as

$$f_g(A) = \int_0^1 x(y) dy, \quad (2.5)$$

where $x(y)$ denotes the fact that x has to be expressed now as a function of y . But $y = G_A(x) = (G(x))^A$, thus $G(x) = y^{\frac{1}{A}}$, and $x = G^{-1}(y^{\frac{1}{A}})$, where G^{-1} denotes the inverse function of G . With this, Equation 2.5 becomes

$$f_g(A) = \int_0^1 G^{-1}(y^{\frac{1}{A}}) dy. \quad (2.6)$$

In the case of the Gaussian-distributed bond strengths, mentioned above, we cannot derive an analytical form for the fitness dependency on antibody library size, as it is impossible to analytically invert the normal distribution. We may, however, compute the values numerically, and this is the approach that I used in generating the data for random antibody libraries shown in Fig. 2.4. As mentioned above, for the case that I studied, the bond strengths are Gaussian distributed, with mean 0, and variance 20.

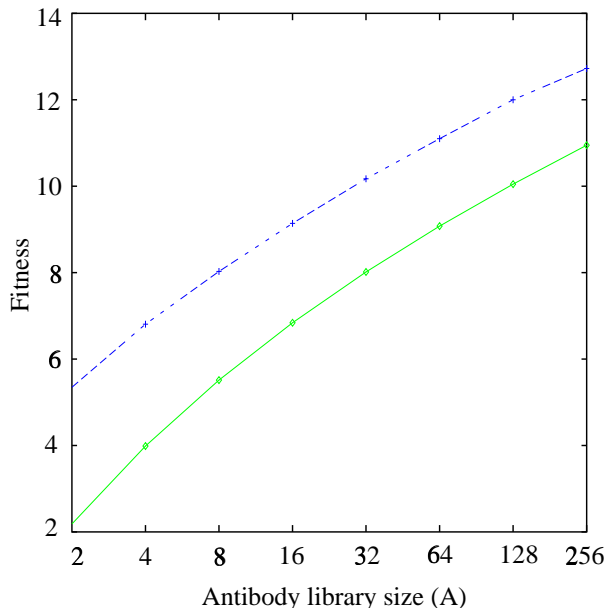

Figure 2.4: Scaling of the fitness with respect to the antibody set size A . The expected fitness of a random library is shown in green, and the fitness of evolved libraries in blue. A population of libraries was evolved for 1000 generations. The points on the curve are averages over 100 (for library size $A = 2, 4, 8, 16, 32, 64$) or 10 (for library size $A = 128$ and 256) independent values of the fitness of the best evolved library. The line is obtained by interpolating between these points.

2.2.2 The fitness and structure of evolved libraries

Fig. 2.4 shows how fitness scales with the library size A for the Gaussian distribution discussed above. As for the shape-space model, the evolved libraries attain a fitness that has a similar functional dependency on the library size as the random libraries. The dependency is sublogarithmic, that is, the fitness increases slower than linear as a function of the logarithm of the library size. The shape-space model, with a binomial distribution of bond strengths, is well approximated by the Gaussian distributed bond strengths, as we expected.

Let us analyze the structure of the evolved libraries. Given the fitness function that we used, we would expect that antibodies that have a high free energy in the unbound state would have the highest chance of lowering their free energy through intermolecular binding. It turns out that the evolved antibodies have higher than average energy. To assess the significance of this difference, we calculate the z-statistic for the evolved antibodies, that is $z = \frac{x-\mu}{\sigma}$, where x is the energy of an evolved antibody, μ is the mean energy of an antibody molecule, and σ is the standard deviation of the energy of an antibody molecule. The evolved antibodies have a z-statistic centered around 2 standard deviations higher than the mean, clearly different from the mean. What this result tells us is that, as expected, the antibodies that were evolved are the equivalent of the "sticky" antibodies,

of high interconnectivity and multispecificity, such as those commonly seen in the immune systems of newborns (see for example Kearney et al. (1992)). These antibodies bind not only to pathogens, but to many other molecules normally present in the body, including DNA and molecules on the surface of lymphoid cells. Thus, the evolutionary algorithm was able to evolve a property known to characterize the immune systems of newborns.

2.2.3 Implications for random antibody libraries

Although I do not have a formal proof, it seems that evolving the antibody libraries allows us to reach higher fitness values than we would have with random libraries, though the functional form of the dependency between fitness and library size does not change. Let us then explore what this functional form might be for a random library, under assumptions about the fitness of individual antigen-antibody interactions that may have biological relevance.

I assume again the random energy model, with all antibody-antigen interactions being characterized by a bond strength distributed according to a density function, g . The cumulative distribution of a single bond strength will be then denoted by G . For example, assume that the bond strength of an antigen-antibody interaction is exponentially distributed, meaning that most interactions are of low energy, higher energy interactions being progressively rare. Then $G(x) = 1 - e^{-\alpha x}$, with α constant. Correspondingly, $G^{-1}(x) = -\frac{1}{\alpha} \log(1 - x)$. Let us denote $y^{\frac{1}{A}}$ by z . Then $y = z^A$, $\frac{dy}{dz} = Az^{A-1}$, and the average fitness over the complete pathogen space will be given by

$$f = -\frac{1}{\alpha} \int_0^1 Az^{A-1} \log(1 - z) dz = \frac{1}{\alpha} \left(\frac{d}{dz} \log(\Gamma(A + 1)) + \gamma \right),$$

which is approximated by $\frac{1}{\alpha}(\log(A) + \gamma)$, with γ being Euler's constant. Thus, in the case where antigen-antibody bond strengths are exponentially distributed, the fitness of a random antibody library scales logarithmically with the size of the library.

We may also consider a long-tailed distribution, such as a power law $G(x) = 1 - x^{-\alpha}$, with α constant. The inverse of this function is $G^{-1}(x) = (1 - x)^{\frac{-1}{\alpha}}$. With the same notation, $z = y^{\frac{1}{A}}$, the average fitness over the complete pathogen space is given by

$$f = \int_0^1 Az^{A-1} (1 - z)^{\frac{-1}{\alpha}} dz = \frac{\Gamma(A + 1)\Gamma(1 - \frac{1}{\alpha})}{\Gamma(A + 1 - \frac{1}{\alpha})}.$$

Expanding $\frac{\Gamma(A+1)}{\Gamma(A+1-\frac{1}{\alpha})}$, we obtain for the average fitness

$$f = A^{\frac{1}{\alpha}} \left(1 - \frac{1}{\alpha} \left(1 - \frac{1}{\alpha} \right) \frac{1}{2A} + O\left(\frac{1}{A^2}\right) \right).$$

Summarizing, when the bond strengths are exponentially distributed, fitness grows logarithmically with the antibody library size; when the distribution is Gaussian, with faster than

exponential tail, the fitness grows more slowly than logarithmically; and for a power law, the fitness is also a power law of the library size. The average fitness, then, as a function of the library size, has a functional form that is the inverse of the density function for the bond strength between an antibody and an antigen. We can use this framework to treat any distribution of antibody-pathogen bond strengths, as more data on this type of molecular interactions becomes available. This is an important feature, as the shape-space based models (and the results that depend on them) have often been criticized for being too restricted, and possibly unrealistic for analyzing biological data.

What may we conclude from this study? It is so far unclear what role the germline diversity plays in the generation of the immune repertoire. Based on the results that I presented here, I argue that adding more and more antibodies to the germline-encoded repertoire is unlikely to improve by a significant amount the survival probability of the host in an unbiased, very large, pathogenic environment. Clearly, with a logarithmic increase in fitness as a function of the antibody library size, germline diversity is unlikely to have a crucial contribution to the immune repertoire of an individual. This may well be a reason why the V region libraries in various species do not seem to number more than approximately 100 genes. But if the selection pressure for increasing library size is small, what would keep evolution from producing even smaller libraries than those that we observe? One possible explanation is that there is a recognition threshold in the matching between antibodies and pathogens below which recognition does not occur. In this case, some minimal number of antibodies would be required to ensure that at least one has minimal affinity for any given pathogen. Alternatively, one may envisage the pathogen set structured as a distribution of clusters such that different genes in the library would reflect different clusters of pathogens. The fine-tuning of the affinity of antibodies is realized through somatic hypermutation during the first encounter of the organism with that specific pathogen. This last process is known to be very efficient, the affinity of a pathogen-specific antibody may increase by as much as three orders of magnitude within a time span of approximately a month. The hypothesis that the composition of the germline antibody library reflects the commonly encountered pathogens has been proposed for different reasons by Cohn and Langman (1990). It has been so far difficult to test. Extensive data on the V genes that are involved in immune responses to virulent pathogens is not yet available. However, in some well-studied cases, such as *Hemophilus influenzae* in humans (Insel et al., 1992), or *Streptococcus pneumoniae* in mice (Lee et al., 1974), preferential involvement of a small number of V region genes (and light-heavy chain combinations) has been reported, adding credence to the proposed hypothesis.

Recently, Davis et al. (1998) proposed that the diversity of the repertoire for T cell, as well as B cell receptors, resides in the third complementarity determining region, CDR3. In contrast to

CDR1 and CDR2, which are exclusively encoded by the V region, CDR3 gets contributions from the J (and D in the case of the heavy chain, or TCR_{β}) region, as well as from the non-templated nucleotide addition process. These authors proposed that CDR3 is sufficient for an initial binding of the immune receptor to the antigen, and that somatic mutation of CDR1 and CDR2 further improves that affinity/specificity of the interaction. This is an intriguing hypothesis, as it shifts the emphasis from germline and, somewhat, combinatorial diversity to processes that are largely responsible for creating random binding sites. These are end-processing of the gene fragments, and non-templated nucleotide addition. On the other hand, there are indications that these mechanisms are considerably restricted in newborns. Preferential rearrangement of certain combinations of $V - D$ and $D - J$ gene fragments results in a much more restricted repertoire, which is essentially germline-encoded (Feeney, 1992; Gilfillan et al., 1995). It is this repertoire that is crucial for the survival and reproduction of the individual. Thus, although the CDR3 diversity might be sufficient for a diverse antibody repertoire, the hypothesis that I favor stresses the role of CDR1 and CDR2 antigen binding regions in the survival of the organism, particularly in the neonatal stage. Moreover, it is now clear that not all organisms have a large repertoire of CDR3 regions. As mentioned before, in sharks, V-D-J gene fragments are sometimes already linked in the germline, without any possibility of CDR3 diversification. In this situation, we also expect that the germline-encoded gene fragments have the determinant role in covering the species-specific set of pathogens.

Chapter 3

Somatic hypermutation targets the antigen-binding regions of antibody genes

The immune repertoire prior to antigen exposure is clearly important for the initial handling of pathogens. However, one of the defining features of the immune system is that it adaptively improves its recognition of pathogens during ongoing immune responses. As a result, in subsequent encounters with the pathogen, the immune response is much more efficient, such that the infection may not even be clinically apparent. This constitutes the basis for vaccination. The improved antigen recognition in secondary responses is due to the process of affinity maturation.

In species such as mice and humans, B cells that have been recruited in an immune response migrate to lymphoid follicles, where, together with antigen-specific T cells and follicular dendritic cells, they form germinal centers. Here B cells replicate at considerable rates (Hanna, 1964; Zhang et al., 1988; Liu et al., 1991). Moreover, mutations are introduced in the *V* regions of B cell receptors at a rate $10^5 - 10^6$ times higher than background DNA mutation (Weigert et al., 1970; Bernard et al., 1978). The resulting variants are selected on the basis of their affinity for the antigen presented by follicular dendritic cells. The cells that survive this process are recruited for the memory compartment, and have, in general, higher affinity for antigen than germline cells (Berek et al., 1991; Jacob and Kelsoe, 1992; Nossal, 1992). Although the mechanism of somatic hypermutation is not known, there is a wealth of knowledge about its sequence specificity (Lebecque and Gearhart, 1990; Rogozin and Kolchanov, 1992; Betz et al., 1993; Smith et al., 1996; Milstein et al., 1998; Dörner

et al., 1997; Cowell et al., 1998). Moreover, in most systems where somatic hypermutation of B cell receptors has been described (Wilson et al., 1992; Hinds-Frey et al., 1993; Betz et al., 1993; Van der Stoep et al., 1993; Reynaud et al., 1995), the sequence specificity seems to follow similar patterns.

Considering that framework regions satisfy mostly a structural role, while the complementarity-determining regions are responsible for binding the antigen, it would clearly be advantageous to target somatic hypermutation to these latter regions. What is not clear, however, is whether this advantage would be large enough to be selectable, given the multiple sources of stochasticity in immune responses. Evidence for diversity-enhancing selection in the evolution of immunoglobulin CDRs has been presented by Tanaka and Nei (1989). They showed that the rate of nonsynonymous substitution in immunoglobulin CDRs is higher than the rate of synonymous substitution. This suggests that selection must be favoring organisms with diverse immunoglobulin CDRs. The effect that I am setting out to investigate is whether CDRs are not only more diverse, but also more prone to diversification under somatic hypermutation. As I will show in the following sections, such evidence is present in individual *V* region genes not only from mice and humans, but from a variety of species. Moreover, the compositional biases that are responsible for this effect are also present in most of these species. This argues that the mechanism that is responsible for introducing somatic mutations is shared between the species that I studied. In the field of experimental immunology, this issue is currently under debate. At least two different somatic mutation mechanisms are thought exist: one which active in mammals, the other in sharks and frog. Finally, I will analyze the T cell receptors, showing that some, but not all of T cell receptor sequences have compositional features that might be associated with somatic hypermutation.

In the previous chapter, I proposed that germline antibody genes could constitute the substrate of evolutionary learning, such that the antibodies that constitute the naive immune repertoire coarsely map the pathogenic universe. In this chapter I investigate the hypothesis that antibody genes also learn in evolution how to maximize their chances of rapidly producing a highly specific antibody for a given pathogen. I will show that this is realized by differential codon usage between the framework and complementarity-determining regions of the antibody genes. Namely, given a certain functionality of the antibody molecule, which is determined by its amino acid sequence, the codon bias in FRs minimizes the chance of a replacement mutation under somatic hypermutation, the converse being true for CDRs. Numerous studies attempted to demonstrate that the frequency of replacement mutations is higher in CDRs. Only one of these studies (Kepler, 1997) addresses the question of selection for amino acid sequence versus selection for amino acids that are more likely to undergo mutations. However, while this study showed that, overall, there is differential codon usage between FRs and CDRs, this result did not hold for all the antibody gene sets under study.

It was not clear whether the lack of generality was due to the low resolution of the statistical tests employed in the study. In my study, I will make use of large artificial sequence sets, which allow me to design statistical tests on individual antibody gene sequences. I will show that antibody genes from a number of species show differential codon usage bias between FRs and CDRs, such that FRs are expected to undergo significantly lower proportion of replacement mutations than CDRs. The artificial data sets that I construct can be used to investigate the level of mutability optimization in different sequences. In somatic mutation studies, one often is confronted with the question of whether a given number of mutations in the sequence is due to its intrinsic tendency to mutate or to some selection pressure for or against mutations. Such questions can be answered using the approach that I introduce here.

Yet another set of questions that can be answered in my framework have to do with using other substrates than the immunoglobulin gene for somatic hypermutation. These studies are designed to investigate what components in the immunoglobulin gene are required for targeting somatic hypermutation to the immunoglobulin locus. Here one is confronted with the question of whether a low number of observed mutations in the non-immunoglobulin gene is due to a lacking regulatory element, or to an intrinsic low tendency to mutate of the gene used as a substrate. This becomes a trivial question once one has an empirical mutability vector, as I will show below.

The power of the approach that I introduce in this chapter is manifested in a number of other areas as well. I will illustrate this by focusing on two other questions. The first comes from comparative immunology: is the somatic hypermutation mechanism shared between all species? I will show that similar differential codon usage between FRs and CDRs characterize species ranging from sharks to humans. This result argues that, at least among these species, the mechanism for somatic hypermutation is likely to be shared. The second question concerns to somatic hypermutation mechanism itself. I will show that codon bias consistent with low propensity for replacement mutations also characterizes non-immunoglobulin sequences. As these sequences do not undergo somatic hypermutation, this association suggests that the somatic hypermutation mechanism uses components from mutation or repair mechanisms that operate with much wider scope across the genome. Thus, non-immunoglobulin sequences that evolve codon bias to minimize their chance of undergoing replacement mutations in evolution also seem less mutable under somatic hypermutation. I will also show that the somatic hypermutation mechanism picks out the A/T content of a gene. That is, high tendency to undergo replacement mutations is correlated with the content of A and T nucleotides in the gene. This result does not give us the key to what the somatic hypermutation mechanism is, but it may prove useful in narrowing the search for this mechanism. Although the phenomenon that immunoglobulin genes undergo somatic mutation was described almost thirty

years ago Weigert et al. (1970), the mechanism responsible for introducing these mutations has not been identified.

3.1 Calculating the predicted replacement mutability of a sequence

I will use an empirical mutability model, that was inferred from a database of 520 unselected mutations found in 28511 nucleotides sequenced from $J_H - C_H$ and $J_\kappa - C_\kappa$ introns (Smith et al., 1996). Cowell et al. (1998) showed that these data are efficiently described by a mechanism that operates on triplets of nucleotides, the probability that a nucleotide mutates being conditioned on the two flanking nucleotides. Cowell and Kepler (in preparation) inferred from these data the probability of any nucleotide mutating given its identity and the identity of the two nucleotides that flank it in the sequence. For each position in the gene sequence, one can retrieve, from this empirical mutability model, the predicted mutability under somatic hypermutation. In general I will be interested in the replacement mutability, defined as the probability that a nucleotide undergoes a substitution that leads to an amino acid replacement. Silent substitutions may only contribute to CDR or FR functional diversity through second order effects, such as subsequently affecting the mutability of the neighboring nucleotides. Although the mutability of a nucleotide is essentially a probability, I will still use the term mutability for historical reasons (see Kepler (1997)).

The procedure that I designed for calculating an average replacement mutability per nucleotide in a sequence is the following:

- From the empirical mutability matrix I retrieve the mutability of the nucleotide, given its identity and the identity of its two neighboring nucleotides.
- From the empirical transition matrix given in Cowell and Kepler I retrieve the probability of each of the three possible substitutions of the nucleotide.
- Each substitution of the original nucleotide by another has a probability 0 or 1 to lead to an amino acid replacement.
- Then the predicted replacement mutability at a given site is given by the product of the mutability of the nucleotide found in the germline sequence at that position, and the sum, over all three possible substitutions, of the product of the probability of the specific substitution and the probability that the given nucleotide substitution leads to an amino acid replacement.

- I then calculate the predicted average replacement mutability of a nucleotide in the sequence is calculated by taking the average over all sites in the sequence of the replacement mutability per site.

To compare FR and CDR mutabilities, I separately determine the mutability of FR and CDR sites. I will use the same procedure to determine the predicted mutability of artificially-constructed sequences.

3.2 All human immunoglobulin V -region sequences have higher average replacement mutability of CDR nucleotides than of FR nucleotides

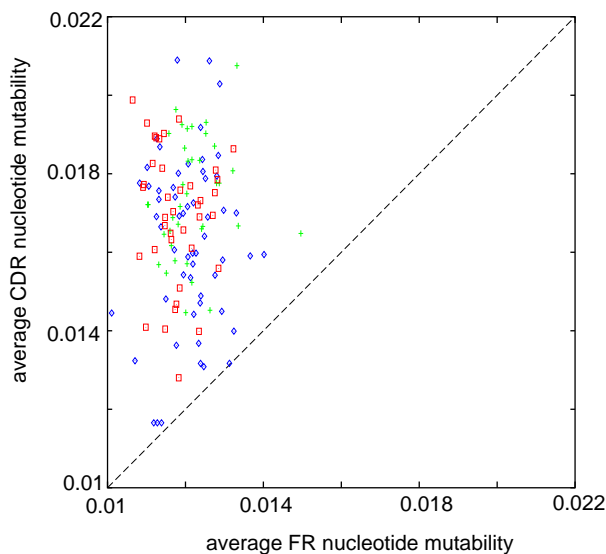

Figure 3.1: Scatter plot of the average FR vs. CDR mutability of human V region genes: V_H sequences ($n = 56$) are shown in blue, V_κ sequences ($n = 37$) in green, and V_λ sequences ($n = 39$) in red.

I extracted the sets of human V -gene sequences from IMGT, the international ImMunoGeneTics database (Giudicelli et al., 1997). In cases where multiple alleles were given for a certain locus, I only considered the first one in the database. I used the CDR/FR assignment given in the IMGT alignments. As we were only interested in the properties of the germline genes, I restricted the analysis to FR1, FR2, FR3, and CDR1, CDR2 fragments. CDR3 is not entirely encoded by germline genes, but contains some non-templated nucleotides, and I therefore left it out of these calculations. As shown in Fig. 3.1, all human V region sequences, heavy as well as light chains,

have higher average replacement mutability of CDR nucleotides than of FR nucleotides.

To investigate what compositional biases are responsible for the difference in FR/CDR mutability, for each of the germline sequences I constructed a number of variant sets: Sets of variants of identical nucleotide composition, codon composition, or amino acid sequence. For illustration, let us focus on one initial data set, the set of human V_H sequences. For each sequence in this set, the set of sequences with identical FR/CDR nucleotide composition can be obtained by permuting the nucleotides in FR and CDR, separately. I constructed 10^5 such variants for each of the germline V_H sequences. If the mutability of a sequence is completely determined by the relative proportion of the nucleotides in the sequence, then we expect that, by permuting the position of the nucleotides in the sequence, its mutability will not be affected. As I will show below, this is not the case. However, for some sequences, the average FR mutability of the set of variants is already lower than their average CDR mutability. Therefore the nucleotide composition does play a role in the differential mutability of FRs and CDRs, although it does not completely explain it.

Similarly, I construct variants of a sequence that have the same codon frequencies in FR and CDR, by permuting the codons, separately, in the two regions. Using this data set I investigate whether the mutability of the sequence is completely determined by its codon composition. If this is the case, the mutability of the germline sequence will not be significantly different than the average over its set of variants. If, on the other hand, the linkage of codons also plays a role, the germline sequence will have a significantly different mutability than the average over its set of variants. Whether the codon composition is sufficient to explain the CDR-FR mutability difference is also a matter of intense debate. My study is the first one that appropriately addresses this question. This is again due to the capability of constructing variants of the sequence whose mutability can be calculated.

Finally, to obtain variants of a sequence with the same translation, I first determined the amino acid sequence encoded by the germline gene. I then generated new nucleotide sequences encoding the same amino acid sequence as follows. For each amino acid, I choose, with uniform probability, one of the codons that could encode it, and add it to the nucleotide sequence. This process is repeated for all amino acids in the protein sequence. For each of the germline sequences, I constructed a set of 10^5 such variants, which I call translationally-neutral (that is, variants with the same amino acid translation). I then used this set to test whether the mutability of the sequence is optimized through codon bias.

Having these variant sets, I could proceed to analyze the mutability of FRs and CDRs in individual V region sequences.

3.3 Statistical analysis on the level of individual sequences

One of the problems that limits the power of analysis of gene sequences is the lack of appropriate controls. For example, for a given immunoglobulin sequence we do not have a set of variants with identical amino acid translation that we can expose to somatic hypermutation to compare their relative propensity to undergo amino acid replacements. Thus, previous studies on differential mutability of FR and CDR of immunoglobulin had to use large sequence sets, and no information could be derived on the level of individual sequences. Such is the case with the serine codon sets segregation pointed out by Wagner et al. (1995), and, more generally, with the segregation of more mutable codons in CDRs (Kepler, 1997). Moreover, these studies were restricted to mutability of in-frame triplets, and did not use all the mutational information that might be present in the database of non-selected mutations. All these problems are circumvented in the approach that I introduced above.

The information concerning one sequence may be visually represented in the following way. Each variant sequence corresponds to a point in the plane of FR/CDR mutability. By taking the minimum and maximum FR and CDR mutability achieved by the variant sequences, one can isolate a rectangle in this plane. I divided this rectangle into 100 by 100 smaller rectangles, which I call bins. If one counts the number of variant sequences falling into each of the bins, one obtains a two-dimensional histogram. By sectioning the two-dimensional histogram at the level of 1, 10, and 100 sequences per bin, one obtains the contour plots that are shown in the figures. The outermost contour line corresponds to densities of 1 sequence per bin, and the innermost one to densities of 100 sequences per bin.

The possibility of analyzing the mutability of individual sequences allowed me to attempt a more detailed understanding of the selection pressures that operate on individual genes. For example, take a light chain sequence, $V_{\kappa}A2$, the predominant germline gene used in the immune response to *Haemophilus influenzae* in humans (Insel and Varade, 1998). Its predicted average FR and CDR nucleotide mutabilities are 1.2%, and 1.57%, respectively, thus a CDR nucleotide is expected to undergo a replacement mutations 1.3 times more often than a FR nucleotide. Fig. 3.2 shows a contour plot of the distribution of three sets of variants of this sequence in the FR-CDR mutability space. The set of sequences with similar FR/CDR nucleotide composition is represented in black, the set of sequences with similar codon composition in blue, and the translationally invariant set in green. The position of the observed germline sequence is represented by the red dot. Of all the artificial data sets, the set with identical codon composition has a mean FR/CDR mutability that is most similar to that of the germline sequence. This allows me to conclude that the mutability pattern of the observed $V_{\kappa}A2$ is best predicted by its codon composition. The CDR mutability

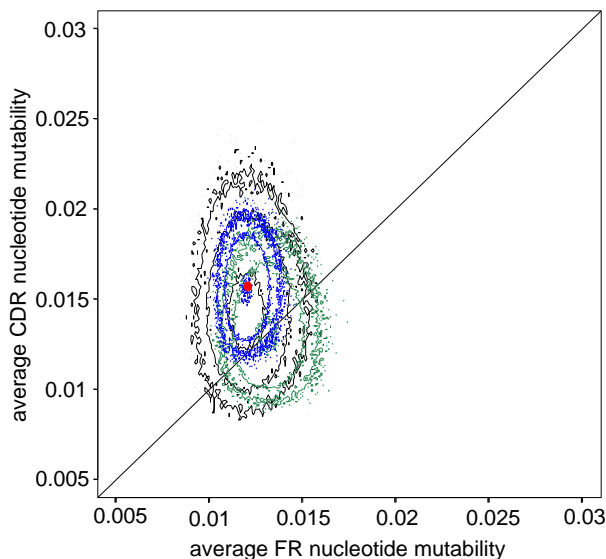

Figure 3.2: Contour plot of the predicted average FR vs. CDR mutability of $V_{\kappa}A2$ variants: 10^5 sequences with similar nucleotide composition (black), 10^5 sequences with similar codon composition (blue), and 10^5 sequences with identical amino acid translation (green). The contour levels are drawn at 1, 10, and 100 sequences. The germline gene is shown in red.

is slightly higher than one could predict from its nucleotide sequence, and I find codon usage bias consistent with low FR and high CDR mutability. Insel and Varade (1998) found a low number of mutations in the complementarity-determining regions of $V_{\kappa}A2$. Their analysis concluded that this was not due to intrinsically low propensity of this sequence, and conjectured that mutations must be negatively selected. My results support this hypothesis, as I also find that $V_{\kappa}A2$ CDRs do not have a low propensity to undergo somatic mutation.

I will take another example, of a V_H germline sequence, VH1-18. The predicted average replacement mutabilities of a FR and a CDR nucleotide from this sequence are 1.28%, and 1.85%, respectively. A CDR nucleotide is thus 1.45 times more likely to undergo a replacement mutation than a FR nucleotide. As shown in Fig. 3.3, the difference in composition between FR and CDR is reflected in their mutability. All variant sets have, on average, higher CDR than FR nucleotide mutability. The amino acid sequence of VH1-18 is such that, regardless of specific codon usage, most of the translationally neutral variants of this sequence would have higher replacement mutability of CDR nucleotides than of FR nucleotides. Moreover, the specific codons that are used in the CDRs would be extremely mutable, regardless of their sequentialization.

The picture changed dramatically when I analyzed a VH2 family gene, VH2-26 (Fig. 3.4). The FR and CDR mutability values of this sequence, 1.24% and 1.32%, respectively, are well predicted by its nucleotide composition. Moreover, the frequencies of the different codons used in this

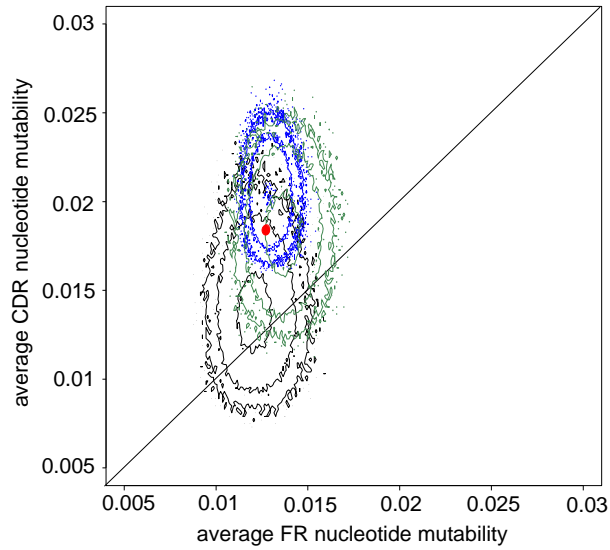

Figure 3.3: Contour plot of the predicted average FR vs. CDR mutability of VH1-18 variants: 10^5 sequences with similar nucleotide composition (black), 10^5 sequences with similar codon composition (blue), and 10^5 sequences with identical amino acid translation (green). The contour levels are drawn at 1, 10, and 100 sequences. The germline gene is shown in red.

sequence seem to be well predicted by the nucleotide composition of the sequence. The amino acid sequence of VH2-26, on the other hand would lead, on average, to lower CDR than FR nucleotide mutability. Thus, as was the case with $V_{\kappa}A2$ and VH1-18, the mutability of VH2-26 is best predicted by its codon composition. In contrast with the previous two sequences though, the amino acid sequence of VH2-26 would result in lower CDR than FR mutability if the codon usage was unbiased. Thus, for this sequence, the codon bias is crucial for the CDR-FR mutability difference.

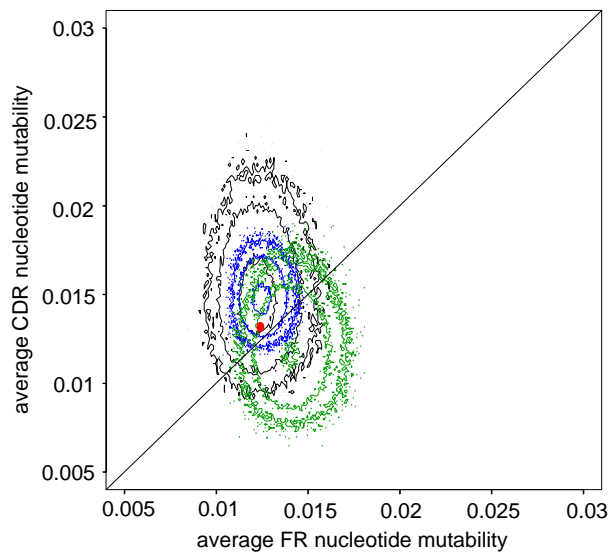

Figure 3.4: Contour plot of the predicted average FR vs. CDR mutability of VH2-26 variants: 10^5 sequences with similar nucleotide composition (black), 10^5 sequences with similar codon composition (blue), and 10^5 sequences with identical amino acid translation (green). The contour levels are drawn at 1, 10, and 100 sequences. The germline gene is shown in red.

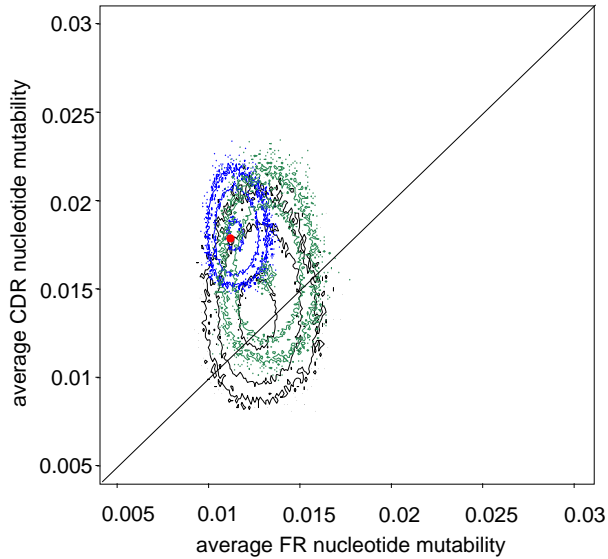

Figure 3.5: Contour plot of the predicted average FR vs. CDR mutability of VH6-1 variants: 10^5 sequences with similar nucleotide composition (black), 10^5 sequences with similar codon composition (blue), and 10^5 sequences with identical amino acid translation (green). The contour levels are drawn at 1, 10, and 100 sequences. The germline gene is shown in red.

Insel and Varade (1998) analyzed the pattern of somatic mutations in non-productive rearrangements of V_{H6-1} , the only member of the 6th V_H family, and argued that the CDRs of this sequence are inherently more mutable. My analysis confirms this result (Fig. 3.5). The average replacement mutability of a CDR nucleotide in VH6-1 (1.77%) is 1.6 times higher than the average replacement mutability of a FR nucleotide (1.1%). Moreover, the CDR amino acid sequence would have high replacement mutability regardless of codon usage. The codon usage, however, further enhances the CDR-FR mutability difference, mainly through low FR mutability. I thus conclude that selection pressure for low FR mutability operates on VH6-1.

The results of this type of analysis on all human V_H sequences are summarized in Table 3.3, which lists the normalized rank of the observed, germline, sequence, among the 10^5 variants of each type. I denoted by μ_F the average FR mutability of a sequence, by μ_C the average CDR mutability, and by μ_F/μ_C the ratio of these two quantities. Note the significant codon usage bias of VH6-1, leading to low predicted FR mutability.

Table 3.1: Normalized ranks of individual V_H sequences.

Gene	Nucleotide permutations			Codon permutations			Translationally invariant		
	μ_F	μ_C	μ_C/μ_F	μ_F	μ_C	μ_C/μ_F	μ_F	μ_C	μ_C/μ_F
human V_H1 genes									
IGHV1-18	0.783	0.976	0.914	0.396	0.074	0.134	0.154	0.536	0.729
IGHV1-2	0.725	0.776	0.662	0.582	0.168	0.17	0.093	0.107	0.331
IGHV1-24	0.617	0.225	0.207	0.236	0.11	0.184	0.0745	0.6	0.797
IGHV1-3	0.861	0.92	0.783	0.639	0.078	0.077	0.287	0.478	0.598
IGHV1-45	0.896	0.84	0.66	0.735	0.241	0.177	0.351	0.118	0.175
IGHV1-46	0.805	0.969	0.898	0.134	0.359	0.566	0.191	0.709	0.824
IGHV1-58	0.815	0.779	0.637	0.474	0.477	0.485	0.221	0.552	0.65
IGHV1-69	0.878	0.885	0.731	0.49	0.561	0.563	0.19	0.787	0.863
IGHV1-8	0.837	0.47	0.313	0.257	0.07	0.142	0.154	0.137	0.292
IGHV1-f	0.931	0.8	0.547	0.66	0.187	0.163	0.344	0.529	0.61
human V_H2 genes									
IGHV2-26	0.549	0.177	0.193	0.445	0.04	0.082	0.034	0.783	0.943
IGHV2-5	0.463	0.484	0.508	0.548	0.317	0.311	0.014	0.742	0.94
IGHV2-70	0.426	0.571	0.599	0.365	0.243	0.343	0.007	0.907	0.991
human V_H3 genes									
IGHV3-11	0.74	0.95	0.872	0.564	0.762	0.717	0.055	0.922	0.977
IGHV3-13	0.829	0.866	0.725	0.906	0.477	0.284	0.42	0.776	0.79
IGHV3-15	0.592	0.554	0.498	0.415	0.192	0.238	0.24	0.61	0.708
IGHV3-16	0.159	0.216	0.397	0.472	0.286	0.307	0.019	0.579	0.826
IGHV3-19	0.227	0.221	0.364	0.507	0.294	0.308	0.061	0.564	0.76
IGHV3-20	0.178	0.363	0.555	0.516	0.07	0.081	0.018	0.6	0.895
IGHV3-21	0.481	0.995	0.987	0.504	0.787	0.752	0.03	0.991	0.999
IGHV3-23	0.815	0.953	0.858	0.721	0.322	0.256	0.126	0.941	0.971
IGHV3-30.3	0.766	0.849	0.687	0.678	0.438	0.371	0.088	0.956	0.987
IGHV3-30	0.679	0.752	0.634	0.608	0.576	0.515	0.097	0.938	0.975
IGHV3-33	0.594	0.862	0.789	0.606	0.542	0.488	0.026	0.916	0.984

Table 3.1: Normalized ranks of individual V_H sequences (continued).

Gene	Nucleotide permutations			Codon permutations			Translationally invariant		
	μ_F	μ_C	μ_C/μ_F	μ_F	μ_C	μ_C/μ_F	μ_F	μ_C	μ_C/μ_F
IGHV3-35	0.254	0.211	0.342	0.367	0.279	0.345	0.037	0.571	0.799
IGHV3-38	0.523	0.819	0.785	0.37	0.224	0.294	0.039	0.856	0.954
IGHV3-43	0.388	0.731	0.753	0.467	0.367	0.393	0.058	0.867	0.961
IGHV3-47	0.614	0.981	0.952	0.434	0.715	0.727	0.131	0.986	0.994
IGHV3-48	0.76	0.995	0.966	0.663	0.924	0.864	0.136	0.995	0.997
IGHV3-49	0.627	0.888	0.815	0.678	0.096	0.09	0.204	0.767	0.854
IGHV3-53	0.495	0.983	0.97	0.341	0.527	0.605	0.022	0.878	0.975
IGHV3-64	0.77	0.955	0.872	0.734	0.447	0.356	0.177	0.955	0.971
IGHV3-66	0.629	0.978	0.944	0.395	0.479	0.533	0.059	0.899	0.967
IGHV3-7	0.741	0.759	0.603	0.737	0.516	0.411	0.071	0.89	0.962
IGHV3-72	0.197	0.966	0.977	0.269	0.686	0.77	0.038	0.893	0.979
IGHV3-73	0.504	0.967	0.943	0.656	0.53	0.456	0.022	0.863	0.969
IGHV3-74	0.555	0.957	0.92	0.657	0.635	0.552	0.063	0.971	0.992
IGHV3-9	0.306	0.813	0.848	0.639	0.258	0.226	0.036	0.966	0.994
IGHV3-d	0.574	0.742	0.692	0.383	0.226	0.291	0.124	0.82	0.909
human V_{H4} genes									
IGHV4-28	0.415	0.936	0.923	0.293	0.357	0.489	0.001	0.59	0.933
IGHV4-301	0.625	0.964	0.923	0.35	0.005	0.049	0.031	0.472	0.779
IGHV4-302	0.545	0.79	0.751	0.228	0.034	0.121	0.019	0.493	0.775
IGHV4-304	0.477	0.971	0.952	0.254	0.009	0.095	0.01	0.63	0.912
IGHV4-31	0.64	0.962	0.918	0.336	0.006	0.05	0.041	0.466	0.76
IGHV4-34	0.359	0.837	0.851	0.146	0.224	0.427	0.006	0.686	0.931
IGHV4-39	0.424	0.993	0.984	0.312	0.459	0.577	0.006	0.806	0.976
IGHV4-4	0.245	0.985	0.986	0.294	0.7	0.767	0.001	0.644	0.961
IGHV4-59	0.308	0.977	0.975	0.236	0.22	0.406	0.003	0.543	0.907
IGHV4-61	0.31	0.992	0.99	0.227	0.125	0.327	0.003	0.76	0.972
IGHV4-b	0.31	0.987	0.985	0.127	0.192	0.461	0.004	0.685	0.953
human V_{H5} genes									
IGHV5-51	0.791	0.996	0.977	0.599	0.934	0.903	0.065	0.917	0.975
IGHV5-a	0.888	0.997	0.967	0.596	0.938	0.901	0.21	0.975	0.981
human V_{H6} gene									
IGHV6-1	0.041	0.966	0.994	0.214	0.356	0.573	0.008	0.855	0.987
human V_{H7} genes									
IGHV7-41	0.453	0.886	0.869	0.24	0.131	0.264	0.012	0.193	0.601
IGHV7-81	0.893	0.515	0.319	0.522	0.005	0.014	0.26	0.015	0.043

3.4 Contribution of nucleotide composition, codon composition and codon usage bias to the predicted FR and CDR replacement mutability of human V_H sequences

Understanding the contribution of various factors to the mutability of *a whole set* of V region sequences cannot be done using the information that I have generated for individual sequences. These sequences arose from gene duplications, probably undergo gene conversion, and thus we expect that their mutabilities are correlated. To get around this problem, I designed another test. Instead of constructing independent permutations of the sequences, I construct permutations that do not alter the correlations of codon usage in various genes. This may be achieved by aligning the sequences and then permuting whole columns in the alignment. A column should be one nucleotide in width if we are to construct variants that preserve the nucleotide composition. Similarly, a column should span a whole codon (3 nucleotides), if we want to obtain variants that preserve the codon composition. Finally, for the translationally neutral variants, I take each codon column in the alignment, and identify the amino acids that appear at the position in the alignment. For each of these amino acids I construct a permutation of codons. Finally, going through all sequences, I replace the codon that is present at that position in the germline sequence, with the one that corresponds to it in the permutation. I repeat repeat this process for each amino acid position in the alignment. I constructed 10^4 variant sets for each of these tests, determined the predicted FR and CDR mutability for each of the sequences in the set, and then averages these quantities over the set. The contour plot of the set average of replacement mutability per FR and CDR nucleotide is shown in Fig. 3.6. These tests allowed me to conclude that the nucleotide composition of CDRs creates motifs with higher replacement mutability than that of the FRs. The set of CDR codons, which is a subset of the motifs that can be created given the nucleotide frequencies, is also a highly mutable subset. Also, the amino acid sequence of human V_H genes has on average higher CDR replacement mutability, regardless of what the codon usage of these genes might be.

Where does the set of real V_H sequences stand with respect to these variants (the average FR/CDR mutability of the germline sequence is represented in Fig. 3.6 by the red dot)? It has significantly higher CDR mutability than would be predicted from the CDR nucleotide composition: If we do a rank test of the average FR and CDR mutability, the normalized rank values that we obtain are 0.6233 for FR, and 0.9925 for CDR. It is not significantly different than the sets with identical codon composition, the CDR codon composition already rendering these regions highly mutable (normalized ranks 0.4246 for FR, and 0.1612 for CDR). This last test also tells us that the exact way the codons are follow each other in the sequence does not play a significant role in FR or

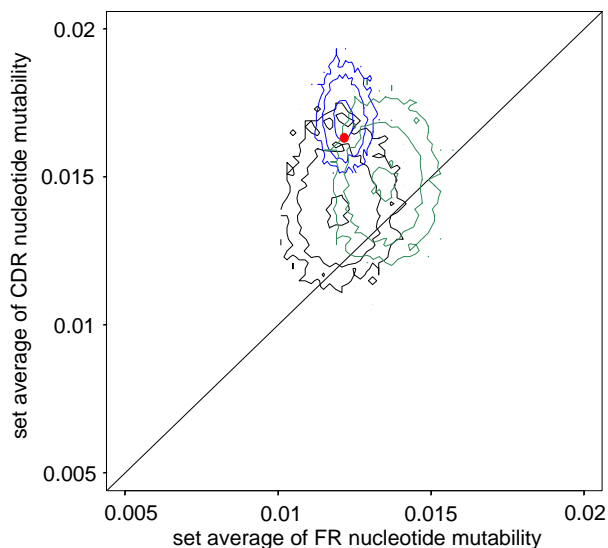

Figure 3.6: Contour plot of the average FR vs. CDR mutability over sets of variants of human V_H sequences. 10^4 sets with similar nucleotide composition (black), 10^4 sets with similar codon composition (blue), and 10^4 sets with identical amino acid translation (green) were used to construct the plot. The contour levels are drawn at 1, 10, and 100 sequences. The germline sequence set is shown in red.

CDR mutability. Finally, given their amino acid sequence, the germline genes show clear codon usage bias, for both FRs and CDRs. We find evidence for both FR mutability minimization (normalized rank of the germline sequence set 0.0061) and for CDR mutability maximization (normalized rank of the germline sequence set 0.9566).

I can also clarify the effect of the serine codons on the mutability of human V_H sequences. All amino acids, with the sole exception of serine are encoded by codons that are accessible from one another via a sequence of single point mutations. Thus, codon bias may evolve without changing the functionality of the protein product. For serine, this is not possible. This amino acid is encoded by six codons, of the type TCN and AGY (A,C,G,T being the four nucleotides, N standing for any of the four, and Y for purines, A and G). To go from the TCN codons to AGY requires two point mutations. Thus if in an ancestral sequence serine is encoded by a TCN codon, changing this into an AGY codon requires going through a non-serine amino acid. The consequence is that for serine we cannot disentangle selection for the specific amino acid from the development of a codon bias. Leaving out the serine codons in calculating the mutability of FRs and CDRs, I perform the same rank test of the germline sequence set with respect to its translationally neutral variant sets. What I find is that the predicted FR mutability remains significantly lower than the average of the variant sets with the same translation (normalized rank 0.0035), whereas the predicted mutability of the CDRs decreases considerably (normalized rank 0.1158). The CDR mutability remains, however,

quite high, but the effect is not due to codon usage bias. Other factors that seem to be responsible for this high CDR mutability are the use of amino acids whose codons are highly mutable motifs such as tyrosine, and preferential use of two-fold degenerate amino acids. That is, amino acids that are encoded by only two codons.

3.5 Are human V -region sequences optimized for somatic hypermutation?

Previous studies (Wagner et al., 1995; Kepler and Bartl, 1998), as well as the above analysis showed a segregation of the more mutable codons in CDRs, and less mutable ones in framework regions. This property characterizes all human V region sequences (Fig. 3.1). This is not to say that human V regions have maximal CDR mutability and minimal FR mutability under somatic hypermutation. I can, in fact, construct the exact nucleotide sequence with this property for any of the V region amino acid sequences. However, as I could not assess the significance of the difference in mutability between the observed and the optimal sequence, I designed instead another approach to look at the degree of optimality of the germline sequence. Namely, I explore the neighborhood of the observed germline sequence in the space of silent mutants. These are the sequences to which evolution had most immediate access. I shall describe the new experiment. I start with a germline sequence, and generate 10^4 variants of it, each of the variants differing from the germline sequence by n silent mutations. I calculate the predicted CDR and FR replacement mutabilities, and their ratio, for each of the variants. I then determine the rank of the observed, germline, sequence among its variants. Returning to the set of human V_H sequences, among the 2 mutation neighbors, the proportion of sequences with higher CDR/FR mutability ratio than the germline sequence varies between 38 and 52 percent. Among 10 mutation neighbors, this proportion varies more widely, 25-65%. Among the 50 mutation neighbors, for some germline sequence we find as few as 4% variants with higher ratio, whereas for some other sequence, this proportion is 98.5%. Thus, the germline sequences are far from being optimal with respect to the differential mutability CDR/FR. It is a different issue whether the selection pressure to select for a higher ratio is sufficiently high. For the 2 mutation neighbors, the CDR/FR mutability ratio changes by fractions of a percent, and only for 10 mutation neighbors do we reach the level of percentages of the germline ratio. My conclusion is therefore that, although all human V_H sequences are characterized by lower FR than CDR replacement mutability per nucleotide, the mutability of individual sequences is quite far from optimal.

Table 3.2: Normalized rank of the ratio between the predicted average CDR and FR mutability of observed germline sequences among their 2-, 10- and 50-mutant neighbors.

Gene	2 mutation neighbors	10 mutation neighbors	50 mutation neighbors
human V_H1 genes			
IGHV1-18	0.541	0.532	0.565
IGHV1-2	0.535	0.449	0.261
IGHV1-24	0.599	0.71	0.867
IGHV1-30	0.527	0.505	0.404
IGHV1-45	0.519	0.459	0.226
IGHV1-46	0.529	0.505	0.449
IGHV1-58	0.52	0.495	0.434
IGHV1-69	0.561	0.593	0.726
IGHV1-8	0.501	0.348	0.069
IGHV1-f	0.544	0.562	0.608
human V_H2 genes			
IGHV2-26	0.624	0.752	0.956
IGHV2-50	0.601	0.639	0.796
IGHV2-70	0.641	0.751	0.951
human V_H3 genes			
IGHV3-11	0.525	0.476	0.404
IGHV3-13	0.483	0.447	0.295
IGHV3-15	0.496	0.477	0.377
IGHV3-16	0.514	0.36	0.095
IGHV3-19	0.487	0.359	0.076
IGHV3-20	0.572	0.59	0.583
IGHV3-21	0.503	0.495	0.471
IGHV3-23	0.507	0.477	0.382
IGHV3-30	0.551	0.558	0.714
IGHV3-30.3	0.565	0.627	0.801
IGHV3-33	0.56	0.589	0.702

Table 3.2: Normalized rank of the ratio between the predicted average CDR and FR mutability of observed germline sequences among their 2-, 10- and 50-mutant neighbors (continued).

Gene	2 mutation neighbors	10 mutation neighbors	50 mutation neighbors
IGHV3-35	0.506	0.383	0.122
IGHV3-38	0.501	0.472	0.337
IGHV3-43	0.564	0.606	0.687
IGHV3-47	0.566	0.638	0.882
IGHV3-48	0.494	0.478	0.457
IGHV3-49	0.526	0.586	0.659
IGHV3-53	0.552	0.556	0.569
IGHV3-64	0.488	0.438	0.31
IGHV3-66	0.533	0.528	0.505
IGHV3-7	0.547	0.55	0.616
IGHV3-72	0.542	0.573	0.66
IGHV3-73	0.585	0.61	0.686
IGHV3-74	0.52	0.554	0.648
IGHV3-9	0.576	0.629	0.778
IGHV3-d	0.482	0.418	0.226
		human V_H4 genes	
IGHV4-28	0.557	0.495	0.444
IGHV4-301-4-31	0.531	0.455	0.322
IGHV4-302	0.535	0.477	0.359
IGHV4-304	0.573	0.549	0.584
IGHV4-31	0.519	0.438	0.306
IGHV4-34	0.616	0.606	0.696
IGHV4-39	0.547	0.546	0.612
IGHV4-4	0.607	0.616	0.756
IGHV4-59	0.574	0.545	0.562
IGHV4-61	0.597	0.574	0.671
IGHV4-b	0.582	0.594	0.737
		human V_H5 genes	
IGHV5-51	0.583	0.701	0.954
IGHV5-a	0.598	0.705	0.938
		human V_H6 gene	
IGHV6-1	0.55	0.625	0.804
		human V_H7 genes	
IGHV7-41	0.586	0.53	0.419
IGHV7-81	0.446	0.274	0.015

3.6 Similar mutability pattern in V genes from other species

Using a mutability model that was inferred from mouse sequences to assess properties of human sequences seems justified, given that the features of somatic mutation mechanism in the two species are very similar (Diaz and Flajnik, 1998). It is, however, not clear that the same mechanism is responsible for somatic hypermutation in other species. Evidence for a mechanism that preferentially targets G and C nucleotides in shark (Hinds-Frey et al., 1993) and *Xenopus* (Wilson et al., 1992; Hsu, 1998) immunoglobulins suggests that their somatic hypermutation mechanism might be different from the one described in mice and humans. One way of addressing this issue, in light of the optimization features that I found in human genes, is to ask whether evidence for such optimization can be found in these species as well. This in turn would argue that the somatic mutation mechanisms in all these species might be similar. Two other complete germline sequence sets are available, sheep V_λ and rainbow trout V_H . Both are tabulated in IMGT database. I isolated these sequences from GenBank (accession numbers taken from IMGT). I added to these sets germline V_H sequences from *Heterodontus franciscii* (GenBank accession numbers Z11776-Z11778, and Z11780-Z11792). This last set might not be complete, and I did not perform a complete analysis on it.

The results are intriguing. The predicted CDR mutability is higher than FR mutability in these sequences, similar to human sequences (Fig. 3.7). When I analyze the codon usage of the

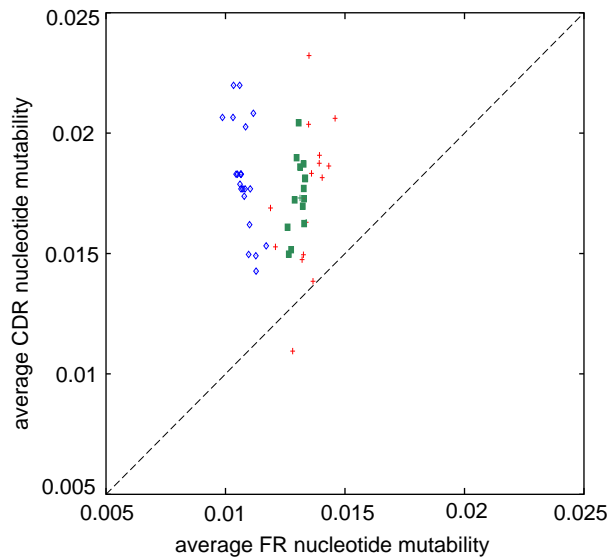

Figure 3.7: The predicted average replacement mutability of CDR vs. FR nucleotides for: sheep V_λ (blue), *Heterodontus* V_H (green), rainbow trout V_H (red).

sheep and trout data sets, I find again evidence for codon bias consistent with low FR and high CDR mutability. The normalized rank of the average FR mutability of the sheep V_λ sequence set

with respect to its translationally neutral variants is 0.0006. For trout, this value is much higher, 0.1. Still, the germline sequence set has an average FR mutability in the lower 10% of what may be obtained with unbiased codon usage. The average CDR mutability of germline sets is significantly higher than that of variant sets with unbiased codon usage in both these species (normalized rank 0.9761 for sheep, and 0.9825 for trout). Excluding the serine codons from the mutability calculations, the effect on CDRs is similar to the effect we observed in human sequences, namely that the rank of CDR mutability goes down (normalized rank 0.4452 for trout V_H sequences and 0.1691 for sheep V_λ). Thus, we again find that serine codons contribute to the high mutability of CDR sequences with respect to their translationally neutral variants. The surprise comes when we determine the FR mutability of trout sequences, for which the exclusion of serine codons from the mutability calculation reduces the normalized rank to 0.0411. Thus, in the framework regions of V_H sequences in trout, serine is encoded by the more mutable codons, AGY, rather than the less mutable ones, TCN. This, in fact, may be a situation where the highly mutable serine codons were “frozen in” the framework regions, due to the fact that a change to a TCN codon would have involved a change of the amino acid at that position. For the other amino acids, we find codon usage consistent with low FR mutability.

The set of *Heterodontus* sequences also has codon usage bias consistent with low FR mutability (normalized rank among translationally neutral variant sets 0.0474), and, like trout sequences, the germline sequence set has even lower FR mutability if we exclude the serine codons from the calculation (normalized rank 0.0123). Contrary to all the data sets we analyzed so far, the CDR mutability of *Heterodontus* sequences, though considerably higher than the FR mutability, is negatively affected by the serine codons (normalized rank 0.6746 with serine codons, 0.8047 without). This is the consequence of serine being encoded mostly by the low mutable codons TCN in *Heterodontus* CDRs.

I performed a similar test on *Xenopus* sequences, only to compare their mutability pattern to those of the *Heterodontus* sequences. As I mentioned previously, there are claims that a different mechanism is responsible for hypermutation in *Xenopus* and sharks as opposed to mammals (Wilson et al., 1992). For *Xenopus*, however, I used cDNA rather than germline sequences. The cDNA is obtained by reverse transcribing the messenger RNA of the cell into DNA. Thus these sequences may have already undergone somatic mutation. I extracted the sequences from Kabat database, accession numbers KADBID004348, KADBID004350-51, KADBID004353, KADBID004356-57, KADBID004359-61, KADBID004365-66, KADBID004371, KADBID004376, KADBID004386. I translated the nucleotide sequences, and then I aligned the amino acid sequences using ClustalW (Higgins and Sharp, 1988)

algorithm running on the European Bioinformatics Institute server in Hinxton (Cambridge, UK), with the default parameters. This alignment was used to infer the CDR/FR assignments.

I find that the high predicted CDR mutability of *Xenopus* sequences (normalized rank 0.9909 among the variant sets with the same translation) is due to a large extent to the usage of highly mutable serine codons, AGY. When I exclude the serine codons from the mutability calculation, the CDR mutability decreases (normalized rank 0.6303 among the translationally neutral variants). There is no evidence for codon usage bias consistent with low FR mutability in these sequences. The normalized rank among the variant sets with identical translation, and unbiased codon usage is 0.4227, or 0.6954, depending on whether I do or do not include the serine codons in the mutability calculation.

The set of sheep V_λ sequences merits particular attention. In sheep, somatic hypermutation seems to be used as a diversification mechanism involved in generating the primary repertoire (Reynaud et al., 1995), presumably without stringent antigen selection. Testing the functionality of the immune receptors that are generated in this manner is probably delayed, allowing a number of mutations to be introduced in the gene. These are likely to render the sequence non-functional. We expect that selection pressure for undergoing a minimal number of FR mutations is operating in these sequences. I thus decided to analyze these sequences individually, looking for evidence for codon usage bias that would render the framework regions of these sequences resistant to replacement mutations. Indeed, I find that the predicted replacement mutability of FR nucleotides is rendered extremely low by the codon bias (Table 3.3).

Summarizing these results:

- Higher predicted mutability of CDR than of FR nucleotides is a general feature in all germline sequence sets used in this study. In addition, I tested that this property holds for two germline sequences of nurse shark antigen receptor (Roux et al., 1998), as well as by V_H cDNA sequences from *Xenopus*.
- With the exception of *Xenopus*, all data sets that I analyzed show evidence for codon bias consistent with low FR mutability. For trout and *Heterodontus* V_H sequences, this bias is stronger if I exclude the serine codons from the mutability calculation. This indicates that the highly mutable serine codons, AGY, are used in the FR regions in these species at high frequencies relative to the low mutable ones, TCN. This seems an interesting situation, in which the highly mutable serine codons have been “frozen into” the sequence during evolution.
- The predicted CDR mutability is invariably high, although different factors contribute to it in different species.

Table 3.3: Normalized ranks of individual sheep V_λ sequences.

Gene	Translationally invariant variants		
	μ_F	μ_C	μ_C/μ_F
SHPIGJVB	0.003	0.911	0.992
AF040900	0.002	0.987	1
AF040901	0.01	0.999	1
AF040902	0.004	0.976	0.998
AF040904	0.031	0.427	0.685
AF040905	0.005	0.999	1
AF040907	0.002	0.975	0.999
AF040908	0.003	0.87	0.982
AF040909	0.015	0.673	0.919
AF040911	0.007	0.913	0.988
AF040913	0.006	0.804	0.96
AF040914	0.022	0.995	1
AF040915	0.008	0.978	0.998
AF040916	0.019	0.673	0.909
AF040917	0.001	0.91	0.991
AF040918	0.001	0.976	0.999
AF040919	0.01	0.672	0.932
AF040920	0.014	0.674	0.921
AF040921	0.006	0.288	0.745
AF040922	0.013	0.701	0.914
AF040923	0.001	0.975	0.999
AF040924	0.003	0.975	0.998

- Contrary to the current view (Diaz and Flajnik, 1998), the mutability pattern of *Heterodontus* V_H sequences resembles that of mammalian, rather than *Xenopus* sequences.

The finding that codon usage bias consistent with low FR and high CDR mutability is present in all but one of the species that I studied, supports the hypothesis that the components of the somatic hypermutation mechanisms are similar in these species. The selection pressures that operate in these different species would be difficult to estimate. It is generally believed that selection is weaker in B cells of *Xenopus* (Wilson et al., 1992; Hsu, 1998), and it is possible that the different mutability pattern in this species comes from lower selection pressure on FR mutability. After all, the CDR mutability is already higher than FR mutability in *Xenopus*, similar to all the other species. We cannot, however, exclude the possibility that different mechanisms are responsible for somatic mutation in *Xenopus*, as opposed to mammalian species.

3.7 Higher predicted replacement mutability of T cell receptor CDRs than T cell receptor FRs

Zheng et al. (1994) isolated individual germinal centers T cells and sequenced their immune receptor genes. Surprisingly, they found a number of mutations in these genes, raising the intriguing possibility that T cell receptors also undergo somatic hypermutation. The mutations that were found in these T cell receptors seemed to bear the mark of somatic hypermutation. That is, only germinal center T cells, already recruited in the immune response were affected, mutations were mostly found in the CDRs and they were concentrated in the hot spots described for B cell receptor hypermutation. This finding challenges one of the basic paradigms of self-nonself discrimination. It is generally believed that during their development in the thymus, T cells that bind any antigen with sufficiently high affinity are destined to die. On the contrary, when T cells bind antigens with high affinity outside of the thymus, they start replicating and performing their effector functions. T cell receptor mutation in the germinal centers may then turn a benign T cell into an auto-reactive one. Evidently, this finding raised a lot of controversy.

Kepler and Bartl (1998), looking for the presence of mutable motifs in T cell receptor CDRs concluded that some of the T-cell receptor chains resemble immunoglobulins in their mutability pattern, but a consistent trend could not be identified. Human TCR V_α did not show the immunoglobulin mutability pattern, whereas murine V_α did, although only when serine codons were excluded. TCR V_β on the other hand, both human and murine, resembled the immunoglobulins.

Given that my results on immunoglobulin sequences are unambiguous, I applied the same analysis to human TCR receptor chains. If the FR/CDR mutability bias of immunoglobulin se-

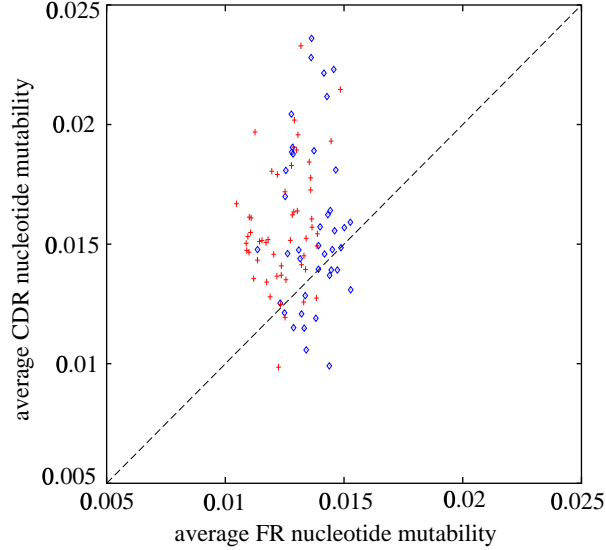

Figure 3.8: Scatter plot of the predicted FR vs. CDR nucleotide mutability values for the set of human TCR_α (blue) and TCR_β (red) sequences.

quences were shared by T cells receptor sequences, we would have indirect evidence that T cell receptor genes also undergo somatic hypermutation, as proposed by Zheng et al. (1994). I used mainly human TCR α ($n = 41$) and β ($n = 54$) chains. The number of γ and δ sequences is considerably smaller (8 and 3, respectively). I used the IMGT alignments and CDR assignments.

Fig. 3.8 shows the scatter plot of the predicted FR-CDR nucleotide mutability for the set of TCR_α (in blue) and TCR_β (in red) sequences. For most TCR_β sequences, the predicted CDR replacement mutability is higher than the FR mutability. For TCR_α this difference is not so clear, many sequences having, in fact lower FR than CDR mutability. Testing for evidence of mutability optimization with respect to somatic hypermutation, I find such evidence for TCR_β , but not for TCR_α . The rank of the set average of FR mutability among 10^4 variant sets with identical translation, but random codon usage, is 0.0103 in the case of TCR_β , and 0.3524 in the case of TCR_α . CDR mutability ranks 0.9581 in the case of TCR_β , and 0.3941 in the case of TCR_α .

These results allow a number of interpretations. They could indicate that somatic hypermutation currently affects T cell receptors, as suggested by Zheng et al. (1994). They could also indicate that the hypermutation mechanism does not operate in these genes currently, but it affected the ancestral receptor from which immunoglobulins and T cell receptors diverged. This feature would then have been preserved in immunoglobulin chains, but lost in T cells, whose sequence drifted away from the one that supported somatic mutation. The mutability pattern of immunoglobulins in other species also argues for somatic mutation being discovered early in phylogeny. This has also been

suggested by M.Flajnik (personal communication, 1998). Finally, this result could indicate that the somatic hypermutation mechanism adapted to the codon bias of immunoglobulin genes. This codon bias could be shared by some of the T cell receptor genes, by virtue of the genealogical relationship between T cell and B cell receptors.

Chapter 4

Non-immunoglobulin genes would have low mutability under somatic hypermutation

As mentioned in the previous chapter, the nature of the somatic hypermutation mechanism is not known. Attempts to show the involvement of mismatch repair mechanisms, that is, the mechanisms that recognize and repair base pairs other than Watson-Crick A-T and G-C, in this process led to ambiguous results (Cascalho et al., 1998; Winter et al., 1998; Frey et al., 1998; Kelsoe, 1998). There is a sense though, that an error-prone polymerase might be involved (Phung et al., 1998), or, more generally, that normally expressed gene products have been recruited in the somatic hypermutation mechanism (Kelsoe, 1998). In order to test the involvement of these general mutation/repair mechanisms in somatic hypermutation, I stated the following hypothesis. If both:

- more general mutation/repair mechanisms have been recruited for somatic hypermutation, and
- genes tend to evolve mutational robustness (Wagner, 1999, and E. van Nimwegen, personal communication, 1999)

then I might be able to detect optimization features with respect to the somatic mutator in non-immunoglobulin genes. Concretely, in light of my previous results, I would expect to detect codon usage bias consistent with low mutability in non-immunoglobulin genes.

In the following sections I will show that such codon bias is indeed present in a large fraction of the non-immunoglobulin sequences that I analyzed. It is not a random codon bias that the

somatic hypermutation mechanism happens to reveal; none of 100 other codon biases that I analyzed produced as many sequences with very low mutability as the codon bias present in the genome. If non-immunoglobulin genes were to undergo somatic hypermutation, they would generally have a low propensity to mutate. A striking finding is that their mutability would be correlated with the A and T nucleotide composition, and that this correlation is not entirely observable in the mutability model that I used. This finding may be a small step towards revealing the nature of the somatic hypermutation mechanism, that virtually every laboratory that studies somatic mutation is trying to identify.

4.1 In non-immunoglobulin genes, predicted mutability is correlated with A/T content

The main mechanisms that have so far been invoked to explain codon usage bias within genomes are concerned with either transcriptional efficiency (Ikemura, 1981, 1985), or with the stability of the nucleic acids, or of the encoded proteins (Bernardi and Bernardi, 1986). In a study of Bernardi and Bernardi (1986), it was shown that codon usage in genomes is determined by compositional constraints. That is, it was shown that the G/C content at the third, degenerate, position of the codons in a gene is correlated with the overall G/C content in the genome compartment where the gene resides. These in turn have to do with the stability of both nucleic acids and proteins, which depend on environmental pressures. Warm-blooded vertebrates have higher G/C content in their genes, which correlates with the stability of mRNA molecules. The amino acid replacements resulting from increasing G/C content have been shown to also lead to more thermodynamically stable proteins (Argos et al., 1979; Zuber, 1981).

With this mechanism in mind, I performed the following test. I used the empirical mutability model described in chapter 3 to calculate an average mutability per nucleotide for a number of non-immunoglobulin genes. I also determined the A/T content of the genes. Surprisingly, mutability is correlated with the A/T-content of the genes. Thus, adjustments in the nucleotide composition of non-immunoglobulin genes, that are associated with higher stability of the DNA and mRNA, seem to correlate with low apparent mutability under somatic hypermutation. This result raises the interesting hypothesis that somatic hypermutation may involve mispairing of nucleotides during DNA synthesis (this event being more probable for A and T nucleotides), the resulting lesion failing to be repaired. Alternatively, it may reflect a bias in the repair mechanism.

For this study, I extracted a set of 140 human non-immunoglobulin genes from GenBank (Appendix A). I performed a pairwise alignment of all amino acid sequences, to ensure that no

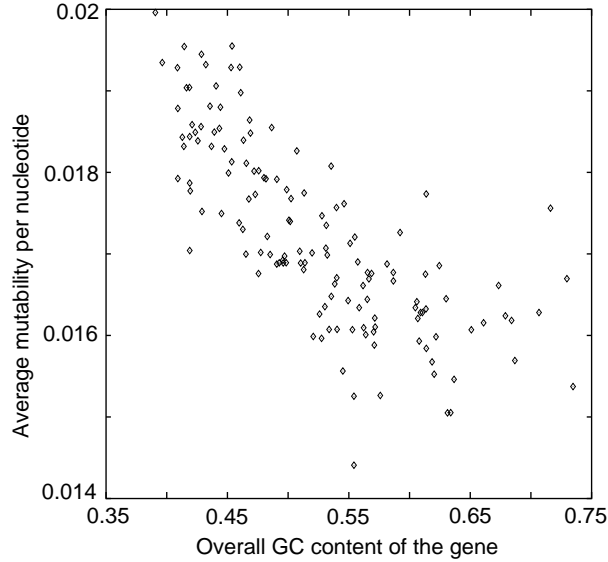

Figure 4.1: Average nucleotide mutability versus the G/C content of the sequence. Each data point represents one non-immunoglobulin sequence.

Table 4.1: Correlation between mutability and A/T content

Data set	Pearson correlation (P-value)	Spearman correlation (P-value)
Triplets	0.293 (0.0187)	0.347 (0.0058)
Non-Ig sequences - total mutability	0.758 (0)	0.82 (0)
Non-Ig sequences - replacement mutability	0.846 (0)	0.873 (0)

close relation existed between any two sequences. That is because I want to assess the significance of the biases that are found in random genes in the genome, and this biases should not be due to the genealogical relationship between sequences. I first determined the total mutability (both silent and replacement) per nucleotide for all these sequences. As shown in Fig. 4.1, the mutability of a sequence is anti-correlated with the G/C content of the sequence. The correlation becomes even more significant when I calculate the replacement mutability rather than total mutability of a nucleotide in each sequence (Fig. 4.2). This correlation can be predicted qualitatively from the mutability matrix that we used. The A/T content of individual triplets (which takes discrete values: 0, 1/3, 2/3, and 1) is already predictive of mutability. However, the correlation is considerably stronger in real genes. Table 4.1 summarizes the results of the correlation test that I performed on triplet mutability, and total and replacement mutability per nucleotide for non-immunoglobulin sequences.

This is precisely what previous studies of mutations that occur spontaneous in the genome

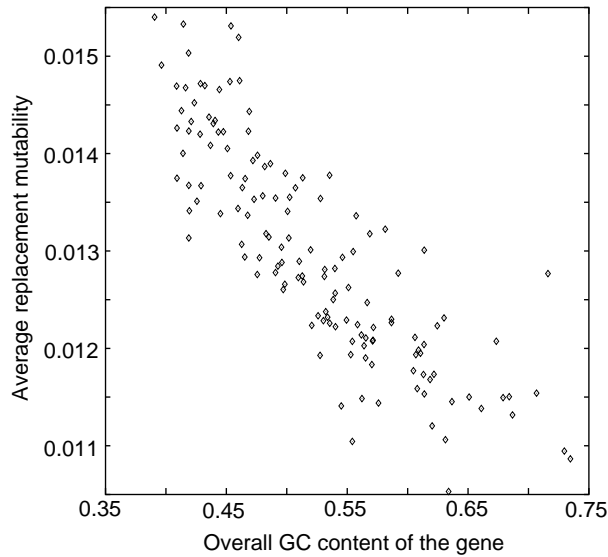

Figure 4.2: Average replacement mutability per nucleotide versus the G/C content of the sequence. Each data point represents one non-immunoglobulin sequence.

evolution reported Bernardi and Bernardi (1986); Wolfe et al. (1989); Li (1997). It is also what we would expect for the somatic mutation mechanism that I studied, given that in the database of mutations from which the mutability values were inferred, adenine was the most frequently mutated nucleotide (Smith et al., 1996). It is not, however, a general finding in somatic hypermutation studies. M. Flajnik (personal communication, 1998), for example, did not find a significant bias in mutation frequencies at different nucleotides. And yet others found a higher mutation frequency at G-C nucleotides (Wilson et al., 1992; Bachl and Wabl, 1996; Varade et al., 1998; Dunn-Walters et al., 1998). At least in one of these cases (Wilson et al., 1992), however, the effect of selection could not be ruled out. The sequence-specificity of the mutator, that is, the mutability of a nucleotide in the context of the surrounding ones, was also not studied rigorously. What my result shows is that, at least in one model of somatic mutation in non-selected sequences (Smith et al., 1996), the sequence-specificity of the mutator induces negative correlation between mutability and the G/C content of a sequence.

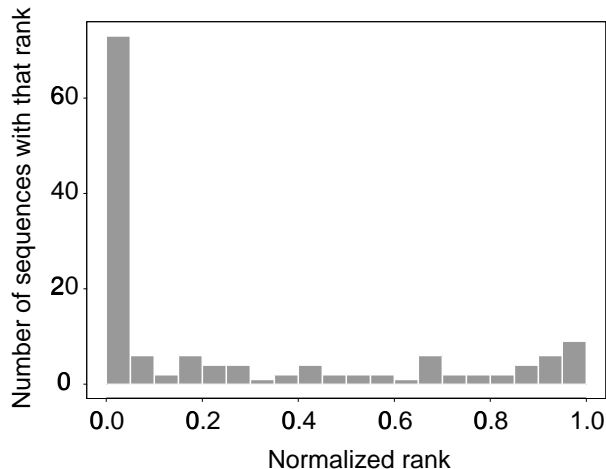

Figure 4.3: Histogram of the normalized ranks of the 140 non-immunoglobulin genes among their translationally neutral variants.

4.2 A significant proportion of non-immunoglobulin genes also have codon bias consistent with low mutability under somatic hypermutation

In the previous chapter, I showed that the codon usage of framework and complementarity-determining regions of immunoglobulin genes is biased, inducing lower mutability of a FR nucleotide compared to a CDR nucleotide. This can be inferred by comparing the mutability of the germline sequence with a set of variants with identical amino acid sequence, but unbiased codon usage. I will apply a similar technique to the set of non-immunoglobulin sequences. Briefly, for each sequence in the data set, I generate a set of 10^4 variants as follows. I translate the nucleotide sequence into its corresponding amino acid sequence. Then, for each amino acid, I choose, with uniform probability, one of the codons that can encode it. I generate 10^4 such variants for each non-immunoglobulin sequence in the initial data set. I calculate their average replacement mutability per nucleotide, and then determine the rank of the mutability of the germline sequence relative to its translationally neutral variants. Fig. 4.3 shows the frequency distribution of the normalized ranks of the 140 genes. Approximately half of the genes in the set have a mutability that is in the low 5% compared to their variants with the same amino acid translation, and unbiased codon usage. As I mentioned, I ruled out any obvious genealogical relationship between these sequences. If their codon usage of the genes was unbiased, we would expect that the distribution of ranks would be uniform. The fact that it is not could indicate two things:

- That a codon usage bias is present in these genes for other reasons, and somatic hypermutation picks out this signal.
- That these genes share a codon usage bias consistent with low mutability because the somatic hypermutation mechanism borrows components from a mechanism that operates with a much larger scope in the genome than immunoglobulin genes.

I attempted to decide between these alternatives using the following test. Let us generate a different codon usage bias. Let C_{ij} be the set of codons, where i denotes the amino acid that the codon j is specifying. Let $P_i(j)$ be a random permutation of the codons encoding amino acid i . Then to construct a sequence under this new codon usage bias, I replace each codon in the sequence C_{ij} by $C_{iP_i(j)}$. The set $P_i(j)$, with $i = 1..20$ constitutes the new codon usage bias. For each codon bias thus constructed, I re-generate the set of 140 gene sequences, and calculate their replacement mutability under somatic mutation. Due to computational constraints, I only generated 100 different permutations of the codons.

As I showed previously (Fig. 4.3), 73 of the 140 non-immunoglobulin sequences that I studied have codon usage that places them in the lowest 5% in mutability among their translationally invariant variants. In fact, 66 of the 140 sequences are in the lowest 1% among their neutral variants. I generate similar sets of translationally neutral variants for each sequence under each codon usage bias. I then determine how many of these codon usage biases give us as many significantly low mutable sequences. It turns out that if I set the significance level at the normalized rank of 1% among the neutral variants, none of the codon usage biases can produce as many low mutable sequences as the original codons usage bias.

This result allows me to conclude that it is not a random codon usage bias that the somatic hypermutation mechanism would pick out of these sequences. It is specifically the codon bias present in the set of germline genes that I used for this study. Thus, there is a significant correlation between the sequence specificity of the somatic hypermutation mechanism and the codon bias present in human genes. This may be due to:

- Somatic mutation being derived from a more general mutation mechanism that operates on the level of the whole genome.
- Somatic mutation having evolved to exploit a codon usage bias already present in the genome.

At the moment, I cannot decide between these two alternatives. On a simplicity argument, I tend to favor the first hypothesis. If the somatic mutator is derived from a more general-purpose mutation mechanism, we would expect that gene sequences, including immunoglobulin gene sequences, already

had low mutability at the time when the mutator appeared. Only codon bias in CDRs would need to be evolved to arrive at the current mutability data. On the other hand, if a whole new mutation mechanism was evolved, it had to first adjust to the codon usage bias of the genome, and then the CDRs evolved a different codon usage. Whether the simplest path was indeed taken in the evolution of the immune system remains to be seen.

Chapter 5

Mutants must be generated and selected in a step-wise fashion during the germinal center reaction

5.1 Affinity maturation during the germinal center reaction

Somatic hypermutation seems to take place only during on-going immune responses, in the germinal center (GC) microenvironment. Germinal centers are specific anatomical sites in lymph nodes, spleen and other secondary lymphoid organs. They have an ephemeral existence, arising during the first week of an immune response, and lasting for approximately four weeks. They are believed to support the process of affinity maturation through somatic hypermutation (Weigert et al., 1970; Bernard et al., 1978) and affinity-based selection (Berek et al., 1991; Jacob and Kelsoe, 1992; Nossal, 1992) of antigen-specific B cells. The term affinity maturation is simply used to describe the observation that the affinity of the antibodies that bind a given antigen at the end of the immune response is higher than the affinity of the antibodies that first reacted to this antigen. Thus the affinity "matures" during an immune response.

A small number of founder B cells (Kroese et al., 1987; Jacob et al., 1991), activated outside of the GC, divide within the GC with doubling times as short as 6-7 hours (Hanna, 1964; Zhang et al., 1988; Liu et al., 1991). These dividing cells, known as *centroblasts*, are concentrated at one pole of the GC known as the *dark zone* (see Fig. 5.1) (MacLennan, 1991). Cells exit the dark zone and rapidly move to an adjoining region of the GC, called the *light zone*. Kinetic studies involving

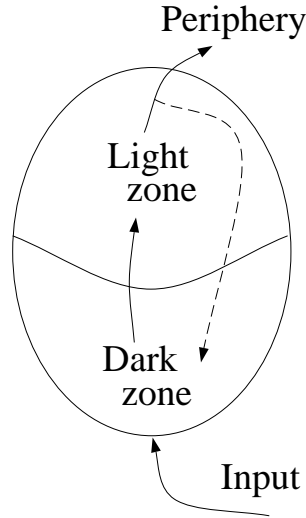

Figure 5.1: Germinal center reaction. B cells divide in the dark zone as centroblasts, then move towards the light zone where they convert into centrocytes. In the light zone, centrocytes undergo selection and then exit the germinal center, or, in recycling models, return to the dark zone for another round of replication

labeling of dividing cells show that centroblasts pick up the label within 2 hours after it has been injected, and then move towards the light zone, where labeled cells appear only after 6-8 hours (Liu et al., 1991). Light zone cells, *centrocytes*, therefore do not appear to be actively dividing, but are generated from dividing centroblasts. The antigen that the cells are selected for seems to be concentrated in the light zone of the germinal centers, on the surface of follicular dendritic cells.

This apparent separation of the proliferative compartment, the dark zone, from the compartment where the antigen is found (and selection supposedly occurs) led to a one-pass picture of the germinal center reaction (MacLennan, 1994). That is, cells were thought to enter the germinal center, divide in the dark zone, move into the light zone, undergo selection, and the surviving cells make it into the memory compartment. The cells produced by somatic mutation and affinity selection have large numbers of point mutations in their immunoglobulin genes. Kepler and Perelson (1993) pointed out that accumulating random mutations to the extent observed in the dominating, high-affinity population, without an intervening selection event, is likely to render cells incapable of binding the antigen. They then performed an optimal control study of affinity maturation in the GC, with the mutation rate being the control variable, and concluded that cycles of mutation-less proliferation followed by mutation and selection, are the most efficient way of creating a memory population with a high average affinity. They suggested that one way to implement this optimal strategy would be to have cells proliferate and then mutate in the dark zone, undergo selection in the light zone, and then return to the dark zone and repeat the process. This model was called

a cyclic re-entry or *recycling model*. A model based on the recycling hypothesis, which took into account the architectural and kinetic details of the germinal center was subsequently developed by Oprea and Perelson (1997). This model assumed that mutation occurs in the replicating population of the dark zone with selection occurring in the light zone. Affinity maturation was achieved with repeated movement between dark and light zones.

Testing the recycling hypothesis turns out to be difficult, as we cannot, at the moment, track the cell migration patterns in the germinal centers. In this context, one might be interested in how much affinity maturation can be achieved in a one-pass selection model. That is, the germinal center is seeded by a few B cells, which start dividing in the dark zone, move into the light zone to undergo selection, and then exit the germinal center, without being able to mutate again. This is exactly the approach that van Nimwegen, Perelson and I took, in order to give an argument "by contradiction" for why selection must be operating at multiple points during the germinal center reaction. Qualitatively, the results of such a model are completely intuitive, the number of high affinity cells has an upper bound which is given by the probability of generating such cells through mutation only. However, it turns out that if the selective agent, that is the antigen, decays during the germinal center reaction the amplification of high affinity cells is even lower than one would expect for affinity-based selection. I think that this result gives even stronger theoretical support to the recycling hypothesis, and also, that it is interesting on its own. There are probably a variety of systems in which the selective agent is decreasing with time, and thus I consider these results worth presenting.

5.2 One-pass selection model of the germinal center reaction

For the specific purpose of the germinal center dynamics, one might be interested in a number of scenarios for the mutation selection process. It is, for example, not known whether mutation occurs during B cell replication or during transcription of the immunoglobulin gene. It is also not known whether the antigen is depleted by B cells, or by other B cell independent mechanisms. All these scenarios give qualitatively similar results, and thus here I will only present one: mutations are introduced at B cell replication, and the antigen decays exponentially with time.

5.2.1 Basic model

We considered germinal center cells falling into two phenotypic classes, centroblasts and centrocytes, and referred to these two pools of cells as the "proliferative compartment" and the "selective compartment". After mutation generates B cell variants, the interactions among B cells, antigen and

T cells, can then be thought of as a filter, selecting for the high affinity cells, and letting the low affinity cells die. The selected cells move into the memory pool and do not re-enter the proliferative compartment of the GC. If there is no feedback from the selective compartment to the proliferative compartment, we can neglect the internal dynamics of the proliferative compartment, and only consider its input into the selective compartment. Thus, we assumed that, due to proliferation, there is a constant flow of B cells into the selective compartment, where antigen is held on the surface of follicular dendritic cells. This assumption is supported by the observation that once the distinguishable light and dark zones could be observed on GC sections, the dark zone did not seem to undergo further expansion (Liu et al., 1991; MacLennan, 1991), suggesting that as cells divide half of the progeny, on average, leave the dark zone.

We group the B cells entering the selective compartment into a small number of affinity classes (Kepler and Perelson, 1993), where all cells in class i are assumed to have similar affinity for the antigen. The number of cells of class i in the selective compartment is denoted by B_i .

The concentration of antigen is denoted by F , and I will only consider here the case of a non-replicating antigen. Antigen within the GC is allowed to decay, the initial concentration being F_0 . At any particular time in the germinal center reaction, $f = F/F_0$ is the fraction of antigen remaining in the GC. While the rate of decay of antigen trapped on follicular dendritic cells (FDC) is not known precisely, measurements by Tew and coworkers (Tew et al., 1979; Tew and Mandel, 1979) and Tew & Perelson (unpublished results) using radioactive protein antigens show approximately exponential decay with half-lives of 1 to 2 months.

We further assumed that the survival of the B cells is the result of their interaction with the antigen, and that the rate of rescue of B cells in class i is proportional to a single factor, s_i . This factor determines the quality of interaction of B cells in class i with FDC-associated antigen when the antigen concentration is maximal. If the antigen decays, we assumed that the rescue rate is proportional to f , the fraction of remaining antigen. One could imagine this factor s_i being proportional to the affinity or the binding rate constant between cells of class i and the antigen, or alternatively, it could denote the amount of antigen that cells of class i manage to present to the T cells. The amount of presented antigen should depend on the affinity of the B cell for antigen, since B cells need to strip the antigen off the surface of FDCs. The model is robust against the specific implementation of the rescue dynamics, as long as rescue of cells in class i is proportional to both the amount of antigen with which they can interact and a single affinity class-specific factor s_i . What we are essentially implementing through this assumption is the view that centrocytes are programmed to die unless "rescued" by the interaction with antigen-loaded dendritic cells, this interaction being affinity-dependent. From now on, the factors s_i will be referred to as affinities, keeping in mind that

there need not be a simple mapping between these factors and the affinity of the B cell receptors for the antigen. However, it seems reasonable to assume that the factor s_i is a monotonically increasing function of the affinity of cells in class i .

Let us denote the number of cells of type i that have entered the memory pool by N_i . I will assume that these cells are long-lived on the time scale of the germinal center reaction, such that no significant loss from this pool occurs during this time period. As I will focus on the efficiency of the germinal center reaction itself, I will not discuss possible dynamics of the memory cell compartment. Affinity selection, and even affinity maturation seem to occur at post-germinal center stages (Takahashi et al., 1998). They do not, however, affect our conclusions on the efficiency of the germinal center reaction.

Under these assumptions, the rate at which rescued cells of class i enter the memory pool is given by

$$\frac{dN_i}{dt} = s_i B_i f. \quad (5.1)$$

If the antigen decays at a constant rate, γ , from an initial amount F_0 to F at time t , the fraction of antigen present in the GC as a function of time is simply

$$f(t) = e^{-\gamma t}. \quad (5.2)$$

As I mentioned above, I will only present here the case of cells mutating when they replicate in the dark zone. Provided that the mutation dynamics is fast with respect to the rate at which FDC-associated antigen is depleted, and that the total influx of B cells into the selective compartment is constant over the duration of the germinal center reaction (MacLennan et al., 1990), we can assume that there is a constant input flux, I , of B cells into the light zone, and that this influx has constant numbers, I_i , of cells in the different affinity classes. Thus, if mutation asymptotically produces a proportion ρ of high affinity cells, then we assume that this proportion occurs in the input to the light zone *from the start* of the germinal center reaction. Note that this is an upper bound on the average affinity of the cells entering the light zone since at the start of the GC reaction fewer high affinity cells might be produced.

Once in the selective compartment, centrocytes get rescued and move into the memory pool, or die at rate μ . Thus, the dynamics of centrocytes of affinity class i is described by

$$\frac{dB_i}{dt} = I_i - \mu B_i - s_i B_i f. \quad (5.3)$$

The first term on the right hand side denotes the constant influx of cells of affinity class i of centroblasts into the selective compartment, the second term accounts for cell death, and the third term for depletion of centrocytes due to their being rescued and converted into memory cells that

exit the GC. We can also take into account the possibility of lethal mutants occurring in B cells at a rate q_l . This would not change the above formulae but would effectively increase the death rate $\mu \rightarrow \mu + q_l$.

5.2.2 Amplification of high affinity cells in the memory population is a logarithmic function of their selection coefficient

Having described the basic model, I will now sketch the derivation of a measure of germinal center efficiency, which I call amplification. This is defined as the ratio between the average affinity of the memory cell pool and the average affinity of the dark zone cells. The first ones constitute the output, the latter the input to the selective filter of the germinal centers.

The antigen dynamics is trivial and simply given by the exponential decay of equation (5.2). The B-cell dynamics is given by equation (5.3). To solve these equations, I will assume that antigen decay is slow compared to the influx, death, and selection dynamics, which amounts to f being constant in equations (5.3). This means that during short periods of time over which the antigen concentration f is roughly constant, the B cells equilibrate to the above values and that these values slowly shift under the change of f as determined by equations (5.4). Under this assumption the centrocytes will reach a quasi-steady state in which

$$B_i = \frac{I_i}{s_i f + \mu}. \quad (5.4)$$

Let us now solve for the number of cells that have entered the memory pool as a function of time for each affinity class, and for the average affinity of the output cells over time. The *output flux* into the memory pool for cells in affinity class i , $O_i(t)$, is given by

$$O_i(t) \equiv \frac{dN_i}{dt} = s_i B_i f = \frac{s_i f I_i}{s_i f + \mu}. \quad (5.5)$$

Substituting f from equation (5.2) we obtain the output flux explicitly as a function of time

$$O_i(t) = \frac{s_i e^{-\gamma t}}{s_i e^{-\gamma t} + \mu} I_i. \quad (5.6)$$

The above expressions demonstrate the main qualitative features of the model. First, the output flux is *at most* as high as the input flux at any time. Obviously, when there is no recycling or division of centrocytes, the number of cells in class i entering the memory pool cannot be larger than the influx I_i of cells in that class. This means that if mutation only creates a small number of cells in high affinity classes, only a small number of high affinity cells can enter the memory pool. Second, the output flux in each class is maximal at the start of the germinal center reaction and decays to zero at late times as antigen decays. Third, the behavior of the output flux $O_i(t)$ of class i is completely

independent of the affinities s_j and input fluxes I_j of cells in the other affinity classes. That is, the output fluxes are not the result of competition between cells. Rather, it is a "competition" between rescue and death that determines the output flux. I will briefly elaborate on this issue, as it seems somewhat controversial at a first reading. Specifically, the notion of competition implicitly assumes some limiting resource, which in this case would be the antigen. Preliminary simulations of this model showed that, for biologically reasonable choices of the parameter values, the cells will rapidly equilibrate with the free antigenic sites on follicular dendritic cells. If at the end of this period there will be free antigenic sites left, then the equilibrium will slowly shift under the independent dynamics of the antigen. If all the antigen is quickly bound by B cells at the beginning of the germinal center reaction, I would expect that the number of high affinity cells that will be generated will be even smaller. In this case, it would not be guaranteed that the few high affinity variants generated during the germinal center reaction will all get to bind the antigen to get rescued. It still seems possible though that the amplification factor will be higher. As I will show below, the number of cells that are generated in a one-pass selection model is already too low to account for the experimental data. Further decreasing these numbers, even with a better amplification of high affinity cells, does not change the basic conclusion that multiple rounds of division, mutation and selection must take place in the germinal centers. However, in the context of a recycling model, the limiting antigen hypothesis would clearly merit consideration.

At all times, the output flux is proportional to the input flux I_i . As long as $s_i e^{-\gamma t} > \mu$, most input cells in class i get rescued. As soon as $s_i e^{-\gamma t} < \mu$, most input cells in class i die, and, as time goes on, the output flux O_i starts decreasing exponentially at the same rate as the antigen. This behavior is illustrated in Figure 5.2 for two affinity classes, class 1 being a high affinity class and class 0 a low affinity class. The output of the zero class drops exponentially from the start, while the output of class 1 cells remains roughly constant for a while and then starts dropping exponentially. Note that the time interval over which $s_i \exp(-\gamma t) > \mu$ and the output flux is roughly constant increases only *logarithmically* with s_i . This feature has important consequences for the efficiency of this type of selection dynamics as will be discussed below. Another thing to note from Fig. 5.2 is that the output per day can be on the order of 1 cell or less, which makes it clear that stochastic finite size effects should be important (for a more detailed discussion see Radmacher et al. (1998)). Therefore, the above results should be thought to represent the *average* output per day, and we expect a stochastic variant of our model to exhibit considerable fluctuations in these numbers. These fluctuations do not, however, alter the conclusions that we can draw from this model.

The total output $N_i(t)$ into the memory pool at time t can be obtained by integrating O_i

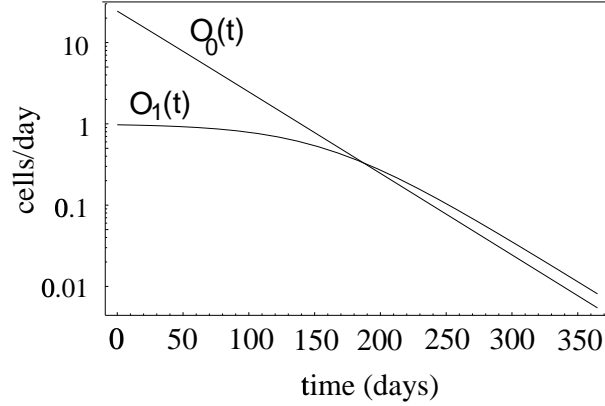

Figure 5.2: The output fluxes $O_0(t)$ and $O_1(t)$ as a function of time. Parameters are $s_0 = 0.1 \text{ day}^{-1}$, $s_1 = 150 \text{ day}^{-1}$, proportion of high affinity cells in the input $\rho = 0.001$, death rate $\mu = 4 \text{ day}^{-1}$, $I = 1000 \text{ day}^{-1}$ and the half-life of the antigen is 30 days.

over time. We find

$$N_i(t) = \frac{I_i}{\gamma} \log \left[\frac{s_i + \mu}{s_i e^{-\gamma t} + \mu} \right]. \quad (5.7)$$

The asymptotic outputs N_i in the limit of $t \rightarrow \infty$ are given by

$$N_i = \frac{I_i}{\gamma} \log \left[1 + \frac{s_i}{\mu} \right]. \quad (5.8)$$

Again, note that the total output of a certain class i is proportional to its input, I_i , and is independent of the affinities and inputs of the other classes, showing that there is no competition between classes. Let us now consider the differential "amplification" of cells in different affinity classes as produced by equation (5.8). Consider an affinity class i for which $s_i \ll \mu$. Most cells in this class will die, so the total output of cells in affinity class i is small. However, since $\log(1 + \epsilon) \approx \epsilon$ for small ϵ the output in class i is roughly proportional to the affinity, s_i . That is, for affinity classes that have an initial rescue rate smaller than the death rate, the output is proportional to the affinity. Next, consider an affinity class j for which $s_j \gg \mu$. For this class, the output is roughly proportional to the *logarithm* of its initial rescue rate s_j . In short, affinity classes with rescue rates below the death rate undergo approximately affinity proportional selection, but affinity classes with affinities above the death rate undergo selection that is only proportional to the logarithms of their affinity. In this way, the affinity maturation that is achieved is largely set by the death rate μ . If most classes have rescue rates above μ the selection will be very weak. The strongest selection occurs when all affinity classes have rescue rates well below the death rate, in which case selection is approximately proportional to affinity. In those cases the total outputs into the memory pool will be small since most cells die. This behavior is shown by all of the one-pass selection scenarios that I mentioned at the beginning of this section.

Let us formally determine the efficiency of the germinal center reaction. I defined this as the ratio of the average affinity $\langle s(t) \rangle_m$ of the memory pool at time t and the average affinity $\langle s \rangle$ of the cells entering the selective compartment. The latter is given by

$$\langle s \rangle = \sum_i s_i \frac{I_i}{I}, \quad (5.9)$$

where I is the total input into the light zone per unit time. The average affinity $\langle s(t) \rangle_m$ of the memory pool at time t is given by

$$\langle s(t) \rangle_m = \sum_i s_i \frac{N_i(t)}{N(t)}, \quad (5.10)$$

where $N(t)$ is the total output into the memory pool at time t . The amplification factor due to selection, $A_s(t)$, will then be

$$A_s(t) = \frac{\langle s(t) \rangle_m}{\langle s \rangle}. \quad (5.11)$$

The asymptotic amplification A_s is given by the limit of the above expression as $t \rightarrow \infty$. Since we know that the most stringent selection occurs when all $s_i \ll \mu$, we can immediately derive an upper bound for the asymptotic amplification. This will also be an upper bound on the amplification at any time during the germinal center reaction. Relation 5.7 could be used in specific cases, when the selection coefficients of different mutants are known, to calculate the affinity amplification at any time t of the germinal center reaction. When all $s_i \ll \mu$, we have for the output in class i

$$N_i = \frac{s_i I_i}{\gamma \mu}, \quad (5.12)$$

from which we can easily derive that

$$A_s = 1 + \frac{\text{var}(s)}{\langle s \rangle^2}. \quad (5.13)$$

This form is typical of affinity proportional selection. The amplification is roughly proportional to $\text{var}(s)$, the variance of the input affinity distribution. In this limit case, the total output into the memory pool N , is given by

$$N = \frac{\langle s \rangle I}{\mu \gamma}. \quad (5.14)$$

5.3 Implications for affinity maturation in the germinal centers

From this one-pass selection model of the germinal center reaction, with the many variants I analyzed, it is clear that the observed numbers of high affinity cells can only be generated if mutant cells are

selected and amplified very often during the germinal center reaction. If, as would be expected from random mutation, there is only a very small proportion of high affinity cells among the cells that enter the light zone, for instance on the order of 10^{-4} , consistent with the estimates of Radmacher et al. (1998), then only a handful of high affinity mutants would be generated over the entire GC reaction. Note that this estimate concerns a simple model antigen, in which one point mutation increases the affinity of the B cell receptor by a factor of 10. If more than one point mutation were required to produce the high affinity mutant, it becomes quite unlikely that a high affinity cell carrying all these mutations would ever be produced. Thus, almost trivially, a low frequency of generation of high affinity mutants restricts the output of high affinity from a germinal center to very low numbers. One might argue that even these small numbers could be expanded to a larger population of high affinity cells. I could envision this happening in two ways. One would be that the selected cells do not exit the germinal center, but can undergo further division in the germinal centers. If centrocytes do not divide, then this scenario reduces to recycling. The second way is that there is an expansion stage between the germinal center and the memory compartment. While this may well be possible, it would only affect the amplification factor that I calculated above if this expansion were associated with affinity selection. Otherwise, the ratio between various affinity classes would not be affected. This case was not considered in the above model, as it would involve a treatment of the dynamics of the memory compartment as well. There is yet another experimental finding that makes the one-pass scenario unlikely. This is the ratio of high affinity cells in germinal centers. While the high affinity mutation is not always discovered within a germinal center, GCs where the high affinity mutation is found have a high proportion of high affinity cells (Radmacher et al., 1998). If the rare high affinity mutants are to dominate the germinal centers, assuming that they do not readily leave the germinal centers, it is necessary that almost all germline cells die. This in turn implies that the total cellular output from a single germinal center dominated by high affinity cells is very low.

When all of the GCs in an animal are considered, one-pass selection can give rise to an appreciable population of memory cells if the stringency of affinity-based selection is low. From stathmokinetic data (Goodlad and Macartney, 1995), I can estimate that the input into the light zone in a fully developed GC is about 1000 cells/day. If this input is sustained for about 2 weeks of the typical 3 week GC reaction, then the 300-500 GCs reported in the splenic response to NP-CGG (Jacob et al., 1991) would have a total light zone input of $4 - 7 \times 10^6$ cells. If 10% of these cells were selected (as we would obtain with the default parameter values from the above model), then the total output from the GCR would surpass 10^5 cells. Even with some cell loss in the periphery, a reasonable size memory population would be achieved. However, this population would consist

mostly of low affinity cells. To generate high affinity cells the stringency of selection would most likely need to be higher. If the frequency at which high affinity cells are generated is 1 per day, and only these cells were selected, then 300-500 germinal centers would produce of the order on 10^3 to 10^4 cells. The frequency at which B cells in an unselected repertoire respond to antigen is 10^{-5} to 10^{-4} . Thus, the total number of initially responding B cells in a mouse with a total of 10^8 B cells is 10^3 to 10^4 . With the higher stringency of selection needed to generate a high affinity memory population, there would be no amplification in the number of responding cells, contrary to the observation of both significantly higher levels of antibody production and higher affinity in secondary responses. Again, this number would be considerably lower if the generation of a high affinity mutant required multiple point mutations.

I would like to point out that systems in which selection is due to an agent that decays over time are more generally encountered in the fields of immunology and infectious disease. Thus, the intuitions built from studying the above model might prove helpful in other situations. These may include, for example, clonal selection of B cells by a non-replicating antigen whose concentration decreases in time, outside of the germinal center reaction. Further examples may include adding fresh media to a culture of growing bacteria and the spread of an epidemic. The selective agent in these cases is the nutrient, in the first case, and individuals that are susceptible to infection, in the latter.

Chapter 6

Mutation rate estimation

During the germinal center reaction, mutations are introduced in the variable region of the B cell receptor gene. Besides being so localized, mutations are also orders of magnitude more frequent than would be expected for a random gene in evolution. Exactly how much more frequent is difficult to estimate, because successive rounds of antigen-based selection may take place (McKean et al., 1984; Kepler and Perelson, 1993). Accurate estimation of mutation rates becomes essential for perturbation experiments that are designed to clarify the role of various genetic elements (such as promoter or enhancer regions) on somatic hypermutation.

6.1 Cell division, cell cycle times

While trying to understand the dynamics of affinity maturation of B cells during the germinal center reaction, Tom Kepler and I decided to look at some simple models of cell culture growth. We started by assuming that all genotypes are selectively neutral, and wanted to estimate the mutation rate in the culture from the proportion of mutants found at the end of the culture period. I wrote a simulation of such a growing culture, based on the assumption that each cell has a certain life time, at the end of which it divides, and each of the two progeny has a probability μ of being a mutant. We soon realized that the currently used method for mutation rate estimation, the fluctuation analysis of Luria and Delbrück (1943), gives an incorrect estimate of the mutation rate in any realistic culture of cells. The reason is that the Luria-Delbrück (L-D) distribution assumes that all cells in the culture have a constant probability of dividing at all times, which amounts to assuming that their cell cycle time is exponentially distributed. This is clearly wrong for any type of cell. This assumption, however, is necessary to make the distribution mathematically tractable. The bias, assuming a gamma-distributed cell cycle time, can be as high as 30%. That the L-D probability function can

be in significant disagreement with the data for more realistic cell-cycle time distributions was first pointed out by Kendall (1952). His rigorous treatment of the problem, however, led to intractable coupled nonlinear integral equations.

What the distribution of cell cycle times is for a particular type of cell is generally unknown, and clearly depends on a variety of external circumstances. Starved cells may persist without dividing for long periods of time (Huisman et al., 1996), while cells that are placed in a chemostat, with abundant supply of nutrients, continue to divide for long periods of time (Travisano and Lenski, 1996). There are two classes of cell-cycle time distributions that have so far been considered in modeling the experimental data. Most of the distributions can be obtained from the gamma distribution, using different parameterizations. Early studies of bacterial cell growth, for example, make this assumption (Kelly and Rahn, 1932), and possible interpretations of it are discussed by Kendall (1952). More recent models of the cell cycle arrive at different distributions of interdivision times. Smith and Martin (1973), for example, introduced a 2-phase model of mammalian cell cycle. According to this model, cells in $G1$ phase of the cell cycle are viewed as being in a state A, from which they have a constant rate per unit time, λ , of transition to phase B. Phase B corresponds to the replication phase of the cell cycle, and is assumed to take a constant time, T_B . Another transition point has been later incorporated in this model (Brooks et al., 1980), and variants of it with a variable B phase have also been proposed (Van Zoelen et al., 1981). In my simulations, I explored both the case of gamma-distributed cell cycle times, and the case of the 2-phase cell cycle.

In this chapter I will present improved methods for estimating mutation rates and constructing confidence intervals, that take into account the cell-cycle time distribution. These methods are valid for the parameter regime of μN , the product of the mutation rate and culture size, being larger than 0, while $\mu \log(N)$, the probability of an individual cell being mutated, being much smaller than 1. This parameter regime covers a large range of experimental systems, while not being addressed by the extant methods of mutation rate estimation. In particular, it covers the germinal center reaction. Although we do not have a general form of the mutant distribution for any type of cell-cycle time distribution, we have reached a number of important goals:

- We have a 0^{th} order estimate of the mutation rate using the mean proportion of mutants in a set of parallel cultures. This method can be used for all the cell-cycle time distributions that we encountered.
- We have a continuum approximation for the Luria-Delbrück distribution which can be calculated more easily than the discrete distribution. The experiments that are designed for mutation rate estimation seem to fall largely in the parameter range for which the continuum approximation holds (see for example Lea and Coulson (1949)).

- We found a way to parameterize the continuum Luria-Delbrück distribution for cultures of cells that have a 2-phase cell cycle. The parameters depend only on the cell-cycle time distribution, and are independent of the mutation rate and cell culture size. This allows us to design a general method for constructing confidence intervals for the mutation rate in this type of cell cultures.
- We found that, if the cell cycle time is gamma-distributed with a given shape parameter, the 5 and 95 percentile values of the proportion of mutants in cultures of known size scales linearly with the mutation rate. I estimated the parameters for the linear fit for cell culture sizes in the range of $10^4 - 10^6$ cells. This is below the experimental range of bacterial culture sizes, but it approaches the culture size for eukaryotic cells. I show how to construct the confidence interval for the mutation rate in this parameter range. However, we are continuing this work, with the goal of finding a culture-size independent method of mutation rate estimation for cultures of cells with gamma-distributed cell cycle times.

Given these results, we are in the position of improving the methodology of mutation rate estimation.

I will first describe the computational model that I designed for testing our theoretical predictions, and for fitting the parameters of the generalized continuum Luria-Delbrück distribution. I will then outline the derivation of the mean proportion of mutants in a culture of a given size, and I will show that the theoretical predictions are well fitted by simulation data.

I will next introduce the continuum approximation of the Luria-Delbrück distribution, due to T. Kepler (Kepler & Oprea, in preparation). This represented the basis for most of our further explorations. I will describe the parameterization that we designed for extending this distribution to fit the simulation data for 2-phase cell cycle times.

I will then show that for gamma-distributed cell cycle times, the 5 and 95 percentile values of the distribution of the proportion of mutants scales linearly with the mutation rate. Thus, even for a culture of cells with gamma-distributed cell cycle, as long as the culture size is not larger than 10^6 , we can still construct confidence intervals for the mean.

Finally, I conclude with a discussion of other issues that arise in estimating mutation rates in bacterial cultures and germinal centers, and I propose ways to circumvent these problems.

6.2 Computational model of a growing culture of cells

The problem that I am trying to solve is to estimate the mutation rate in a culture of cells which is undergoing exponential growth and phenotypic mutations. The basic setup assumed by fluctuation analysis is the following. A culture is seeded with N_0 (generally 1) cells. The culture then grows

exponentially up to N cells. When a wildtype cell divides, each of its progeny has a probability μ of undergoing a mutation that changes its phenotype. In bacteriological experiments, the change in phenotype generally means that the cell will be capable of using a nutrient that a wildtype cell could not metabolize. However, the assay for detecting the mutants is only performed after the growth of the culture. That means that, while the culture is growing, mutant cells do not have a selective advantage over wildtype cells. They grow at the same rate as wildtype cells. It is also assumed that mutants do not revert to the wildtype phenotype, and thus all progeny of a mutant cell will be mutants. When the culture has reached size N , we count the number of mutants, M . Note that lethal mutations are neglected in this analysis. In fact, all the mathematical treatments of this process neglect lethal mutations, as they probably affect only the growth rate of the culture, not the relative proportion of mutant and wildtype cells. Also, neutral mutations fall under the wildtype phenotype, so they do not need a separate mathematical treatment. The question is now, if we have a number of data points (N_i, M_i) , from different cultures that all have presumably the same mutation rate, how do we estimate the mutation rate from these data?

I set up an event driven simulation of the process that I just described. Each cell is represented by an object characterized by its phenotype, wildtype or mutant, and a division time. I seed the system with one wildtype cell of age 0. When a new cell object is created, I assign it a cell cycle time. I explored both types of cell-cycle time distributions that have been used in the literature. The first is the gamma distribution of order q , and scale parameter θ :

$$\phi[t|q, \theta] = \frac{\theta^q t^{q-1}}{\Gamma(q)} e^{-\theta t}. \quad (6.1)$$

The mean cell cycle time is $\langle t \rangle = \frac{q}{\theta}$ and its variance $var(t) = \frac{q}{\theta^2}$. For simplicity, I set the scale parameter to 1 in all cases. This will only be reflected in the absolute values of the cell cycle time, not in their relative ordering. The second type of cell-cycle time distribution that I used I call shifted exponential. That is, there is a constant probability per unit time that the cell starts to divide, λ , but division takes a constant amount of time for all cells, T_B . Then the distribution of cell cycle time is

$$p(t) = \begin{cases} 0 & \text{if } t < T_B \\ \lambda \exp(-\lambda(t - T_B)) & \text{otherwise} \end{cases} \quad (6.2)$$

The mean cell cycle time is in this case $T_B + 1/\lambda$, and the variance in cell cycle time is $1/\lambda^2$. I scaled these parameters such that the mean cell cycle time is 1. That is, only the ratio between the division time and the mean waiting time between two divisions will affect the mutant distribution in the culture, not the absolute values of these times. I will denote this parameter by

$$r = \frac{T_B}{\frac{1}{\lambda}} = \lambda T_B. \quad (6.3)$$

I maintain a priority queue of cell objects, the value used for determining the order of objects in the queue being the absolute value of time at which the cell divides. This in turn is the sum of the cell cycle time of the cell and the time at which the cell was born. At each step of the simulation, the object with the lowest time of division is removed from the queue. Two new objects are created, each having a division time which is the sum of the current time and a cell cycle time drawn from the gamma distribution. With probability μ each of the two daughter cells mutates. These operations are performed for a fixed number of steps, i.e., for $N - 1$ duplications, if we are to achieve a culture of size N . This algorithm implements the dynamics of a culture that grows exponentially from 1 to N cells. Random deviates from a gamma distribution of a given order were generated using the standard Numerical Recipe function (Press et al., 1988). The special case of the shape parameter $q = 1$ gives us deviates from the exponential distribution. At the end of the simulation, I count the number of mutants among the N cell objects. I generate a large number ($10^4 - 10^6$) of replicates of this experiment for constructing the distribution of the proportion of mutants in the culture.

6.3 Mean number of mutants in a culture of size N

For calculating the mean number of mutants in the culture, we used the following approach. We determined the mean number of division events that a cell in the final culture has experienced on the path from the cell that seeded the culture to a cell in the culture of size N . We then calculated the probability that a mutation occurred along this path.

To determine the mean number of divisions, we first determined the growth rate in the culture as a function of the cell-cycle time distribution, and then we used it to determine the mean generation number of a cell in the final culture. I will first outline the derivation of the growth rate in the culture. The age at which any individual cell divides is a random variable, A . For a cell randomly chosen at birth, this age of division is described by the cumulative distribution function Φ defined by $\text{Prob}(A < a) = \Phi(a)$, and, equivalently, by its density function $\phi(a) = d\Phi(a)/da$.

At division, the parent is lost and two cells of age zero are created. Consider a population of such cells. If the density of cells of age a in the population is denoted $y(a, t)$ where t is the absolute time, then the equation for loss of the parent cells by division is

$$(\partial_t + \partial_a)y(a, t) = -h(a)y(a, t), \quad (6.4)$$

where $h(a)$ is given by

$$h(a) = \frac{\phi(a)}{1 - \Phi(a)}. \quad (6.5)$$

Note that we can write

$$h(a) = -\frac{d}{da} \log(1 - \Phi(a)). \quad (6.6)$$

The equation for gain of new cells is derived by integrating Eq.(6.4) over a and demanding that the total rate of production be given by

$$\frac{d}{dt} \int_0^\infty y(a, t) da = \int_0^\infty h(a)y(a, t) da. \quad (6.7)$$

This results in the production equation

$$y(0, t) = 2 \int_0^\infty y(a, t) h(a) da \quad (6.8)$$

We seek solutions to Eq.(6.4) of the form $y(a, t) = \eta(a)\rho(t)$, the so-called separable solutions. Substituting this form into Eq. (6.4), we obtain

$$\frac{d\rho(t)}{dt} \frac{1}{\rho(t)} = -h(a) - \frac{d\eta(a)}{da} \frac{1}{\eta(a)}. \quad (6.9)$$

Note that the right-hand side depends only on a , while the left-hand side depends only on t . Therefore, if this equation is to hold for all values of both t and a , then either side must be constant. If we call this constant α , we have

$$\frac{d\rho}{dt} = \alpha\rho \quad (6.10)$$

and

$$\frac{d\eta}{da} = [-h(a) - \alpha]\eta. \quad (6.11)$$

The solution for ρ is simply

$$\rho(t) = \rho(0)e^{\alpha t} \quad (6.12)$$

while for η we have

$$\eta(a) = \eta(0)(1 - \Phi(a))e^{-\alpha a} \quad (6.13)$$

The condition on α is obtained by substituting Eq. (6.13) into Eq. (6.8) to give

$$\eta(0) = -2\eta(0) \int (1 - \Phi(a)) e^{-\alpha a} \left[\frac{d}{da} \log(1 - \Phi(a)) \right] da. \quad (6.14)$$

Now an integration by parts and use of Eq. (6.6) yields

$$\frac{1}{2} = \int_0^\infty da \phi(a) e^{-\alpha a} \quad (6.15)$$

This is the eigenvalue equation for α that we seek. Since $\phi(a)$ is the density function for cell-cycle time, we can write this last result as

$$\mathbb{E}[e^{-\alpha a}] = \frac{1}{2} \quad (6.16)$$

where E denotes expectation with respect to ϕ . If ϕ is a gamma distribution of shape parameter q and mean τ (Eq. 6.1), then the growth rate is given by

$$\alpha = \frac{q}{\tau} \left(2^{\frac{1}{q}} - 1 \right). \quad (6.17)$$

Note that in the limits that we understand *a priori*, we have agreement with our expectations. For $q = 1$, corresponding to an exponential density function, we should recover a simple Markov model. In this case, we get $\alpha = 1/\tau$. For the limit as $q \rightarrow \infty$, we get a process describing a polymerase chain reaction, with all "cells" replicating at exactly equal times. For this we have $\alpha = \log(2)/\tau$. Both of these results conform to prior knowledge.

The calculation of the mean generation number requires us calculating the mean age of a cell at division. For this, we assume that the culture was in stationary growth from the beginning. That is, we assume that the age distribution in the culture is constant as a function of time. We then calculate the average age at division using the density function for age, $\phi(a)$, but weighted by the proportion of cells of age a in the culture. To determine this, observe that cells that divide, by chance, earlier than usual, will leave, on average, more offspring than those that divide later. If the growth rate is g , i.e., the number of cells grows like $N(t) = N(0) \exp(\alpha t)$, then two cells that divide Δt time units apart will leave different numbers of offspring and the ratio in that number is $\exp(\alpha \Delta t)$. For the simplicity of notation, I will denote $N(0) \equiv N_0$. Following this argument, first given by Fisher (1930), we obtain the average age at division

$$E[a|N] = \frac{E[ae^{-\alpha a}]}{E[e^{-\alpha a}]} \quad (6.18)$$

but in light of the definition of α , we get

$$E[a|N] = 2E[ae^{-\alpha a}]. \quad (6.19)$$

For the specific case of the gamma distribution, parameterized as above

$$E[a|N] = \tau 2^{-1/q}. \quad (6.20)$$

The mean number of divisions is given by

$$E[g|N] = \frac{t}{E[a|N]} = \frac{\log(N/N_0)}{(\alpha E[a|N])} \quad (6.21)$$

which again in the case of the gamma distribution gives

$$E[g|N] = \frac{\log(N/N_0)}{q(1 - 2^{-1/q})}. \quad (6.22)$$

For the exponential distribution, $E[g|N] = 2 \log(N/N_0)$ and for the PCR process, $E[g|N] = \log(N/N_0)/\log(2) = \log_2(N/N_0)$.

We may now calculate the mean number of mutants by assuming that at each cell division, each of the daughters has a probability μ of becoming mutant (and therefore all of her daughters as well). The probability that no mutation occurs in g divisions is $(1 - \mu)^g$, so the probability that at least one mutation occurs is $1 - (1 - \mu)^g$. Then the probability of a cell being a mutant is $\sum_g (1 - (1 - \mu)^g)p(g)$, where $p(g)$ is the probability that the cell underwent g divisions. For small mutation rates, such that $\mu g \ll 1$, this expression can be approximate by $\mu \langle g \rangle$, that is, the probability that an individual cell is mutant is $\mu E[g|N]$. Each of the N cells in the final culture has this chance of being a mutant, thus the mean number of mutants in the culture is $\langle M \rangle = \mu N E[g|N]$. For a gamma distribution of cell-cycle times, this becomes

$$\langle M \rangle = c\mu N \log(N/N_0) \quad (6.23)$$

where the correction factor c is given by

$$c = \frac{1}{q(1 - 2^{-1/q})}. \quad (6.24)$$

We now have an analytical form for the mean number of mutants in a culture of size N , in which the cells have a gamma-distributed cell cycle time.

A similar derivation gives us the correction factor for the mean in the case of a 2-phase model of cell cycle time. Assume that the cell cycle time has a constant component, T_B , and an exponentially distributed part, of parameter λ . Thus, the cell-cycle time distribution is

$$\phi(a) = \begin{cases} 0 & \text{if } a < T_B \\ \lambda \exp(-\lambda(a - T_B)) & \text{otherwise} \end{cases} \quad (6.25)$$

The mean cell cycle time is $T_B + 1/\lambda$, and the variance in cell cycle time is $1/\lambda^2$. The coefficient of variation of this cell-cycle time distribution is

$$r = \frac{1/\lambda}{T_B + 1/\lambda} = \frac{1}{\lambda T_B + 1}$$

Let us derive the mean proportion of mutants in the culture with this new cell-cycle time distribution. Assuming that the culture is in stationary growth, with growth rate α , the number of cells in the culture as a function of time is given by

$$N = N_0 e^{\alpha t}.$$

Conform Eq. 6.15, the eigenvalue equation for the growth rate α is

$$\frac{1}{2} = \int_0^\infty \phi(a) e^{-\alpha a} da,$$

where $\phi(a)$ is the distribution of the age of cells at division. For the shifted exponential cell-cycle time distribution,

$$E[e^{-\alpha a}] = \int_{T_B}^{\infty} p(t)e^{-\alpha t} dt = \int_{T_B}^{\infty} \lambda e^{-\lambda(t-T_B)} e^{-\alpha t} dt = \lambda e^{\lambda T_B} \int_{T_B}^{\infty} e^{-(\lambda+\alpha)t} dt = \frac{\lambda e^{-\alpha T_B}}{\lambda + \alpha}.$$

Thus α must satisfy

$$\frac{\lambda e^{-\alpha T_B}}{\lambda + \alpha} = \frac{1}{2}. \quad (6.26)$$

The solution of this equation can be given in terms of the Lambert's W function:

$$\alpha = -\lambda + \frac{W[2\lambda T_B e^{\lambda T_B}]}{T_B}. \quad (6.27)$$

The average age at division of a cell on the lineage from the root to a leaf in the genealogical tree of the culture is given by Eq. 6.18:

$$E[a|N] = \frac{E[ae^{-\alpha a}]}{E[e^{-\alpha a}]}.$$

From the eigenvalue equation for α , we find (Eq. 6.19)

$$E[a|N] = 2E[ae^{-\alpha a}].$$

The average number of generations from the founder cell to a cell in the current culture is then given by

$$E[g|N] = \frac{t}{E[a|N]} = \frac{\log(N/N_0)}{\alpha E[a|N]} = \frac{\log(N/N_0)}{2\alpha E[ae^{-\alpha a}]}.$$

Now

$$E[ae^{-\alpha a}] = \int_{T_B}^{\infty} a \lambda e^{-\lambda(a-T_B)} e^{-\alpha a} da = \lambda e^{\lambda T_B} \left[\frac{e^{-(\lambda+\alpha)T_B}}{\lambda + \alpha} \left(T_B + \frac{1}{\lambda + \alpha} \right) \right].$$

This can be expressed in a simpler form, given that the growth rate, α satisfies Eq. 6.26. Namely,

$$E[ae^{-\alpha a}] = \frac{\lambda e^{-\alpha T_B}}{(\lambda + \alpha)^2} [T_B(\lambda + \alpha) + 1] = \frac{1}{2} \frac{T_B(\lambda + \alpha) + 1}{\lambda + \alpha} = \frac{1}{2} \left[T_B + \frac{1}{\lambda + \alpha} \right].$$

As before, if we write the mean number of mutants in the culture as

$$\langle M \rangle = c\mu M \log(N/N_0),$$

where c is a function of the cell-cycle time distribution, for the shifted exponential we obtain:

$$c = \frac{\lambda + \alpha}{\alpha [T_B(\lambda + \alpha) + 1]}. \quad (6.28)$$

As expected, if we set $T_B = 0$, we obtain $c = 2$, which is the correction factor for exponentially-distributed cell cycle time.

Table 6.1: Mean proportion of mutants in cultures in which cells have gamma-distributed cell cycle time.

N_0	N	μ	q	Observed mean (S.E.)	Predicted mean
1	10^4	10^{-4}	1	0.001742 (0.000154)	0.001842
1	10^4	10^{-4}	3	0.001417 (0.000134)	0.001488
1	10^4	10^{-4}	10	0.001330 (0.00011)	0.001375
1	10^4	3×10^{-4}	1	0.005128 (0.000207)	0.005526
1	10^4	3×10^{-4}	3	0.004045 (0.000151)	0.004464
1	10^4	3×10^{-4}	10	0.004355 (0.000204)	0.004126
1	10^4	10^{-3}	1	0.017548 (0.000463)	0.018421
1	10^4	10^{-3}	3	0.014822 (0.000366)	0.014882
1	10^4	10^{-3}	10	0.013536 (0.000327)	0.013754
1	10^4	3×10^{-3}	1	0.050005 (0.00068)	0.05262
1	10^4	3×10^{-3}	3	0.043824 (0.000625)	0.044645
1	10^4	3×10^{-3}	10	0.041336 (0.000586)	0.041261
1	10^5	10^{-4}	1	0.002223 (0.000168)	0.002303
1	10^5	10^{-4}	3	0.001702 (0.000084)	0.00186
1	10^5	10^{-4}	10	0.001354 (0.000086)	0.001719
1	10^5	10^{-3}	1	0.023307 (0.000524)	0.023026
1	10^5	10^{-3}	3	0.017987 (0.000349)	0.018602
1	10^5	10^{-3}	10	0.016823 (0.000315)	0.017191

Table 6.2: Mean proportion of mutants in cultures in which the cell cycle time is distributed as a shifted exponential.

N_0	N	μ	r	Observed mean (S.E.)	Predicted mean
1	10^4	10^{-4}	1	0.001784 (0.000176)	0.001425
1	10^4	10^{-4}	3	0.001338 (0.000107)	0.001353
1	10^4	10^{-4}	9	0.00132 (0.00011)	0.001333
1	10^4	3×10^{-4}	1	0.004549 (0.000221)	0.004268
1	10^4	3×10^{-4}	3	0.00397 (0.000176)	0.00402
1	10^4	3×10^{-4}	9	0.003866 (0.000146)	0.004
1	10^4	10^{-3}	1	0.014188 (0.000339)	0.014225
1	10^4	10^{-3}	3	0.013547 (0.000317)	0.013533
1	10^4	10^{-3}	9	0.013415 (0.00033)	0.01333
1	10^4	3×10^{-3}	1	0.041419 (0.000556)	0.042676
1	10^4	3×10^{-3}	3	0.039641 (0.000548)	0.040599
1	10^4	3×10^{-3}	9	0.038854 (0.00052)	0.039991
1	10^5	3×10^{-4}	1	0.005331 (0.000178)	0.005335
1	10^5	3×10^{-4}	3	0.005005 (0.000177)	0.005075
1	10^5	3×10^{-4}	9	0.005172 (0.000168)	0.004999
1	10^5	10^{-3}	1	0.017139 (0.000323)	0.017782
1	10^5	10^{-3}	3	0.017509 (0.00036)	0.016916
1	10^5	10^{-3}	9	0.016393 (0.00029)	0.016663

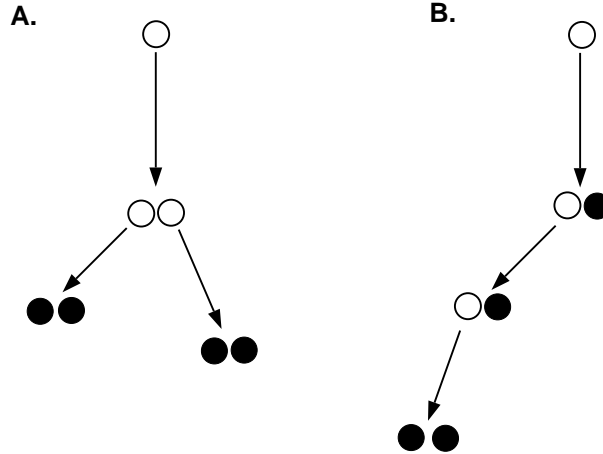

Figure 6.1: Genealogical trees that can be realized in a four-cell culture: the first tree is symmetrical (panel A), the second asymmetrical (panel B). The cells that are present in the final culture are represented by filled circles. Open circles represent cells that have been present in the culture at some point in the growth of the culture, but have since undergone division. The edges denote life times of individual cells.

The mean proportion of mutants as obtained from simulations, together with the theoretical prediction is presented in Tables 6.1 (for the gamma-distributed cell cycle time) and 6.2 (for the shifted exponential). 10000 independent runs were performed for each of the parameter sets.

As can be seen from the tables, there is a good agreement between the means that I obtained from simulations, and the ones that I calculated. It is also apparent that if the cell cycle is exponentially-distributed, the mean proportion of mutants is higher, for the same mutation rate per division, than if the cell-cycle time distribution had a higher order. Turning the argument around, if we assume that the cell cycle time is exponentially-distributed, when in reality it is not, leads to underestimation of the mutation rate. Although this comes out of the expression for the mean, I would like to give an intuitive argument for how the cell-cycle time distribution enters into the mutant distribution.

Assuming that the cells have an exponentially-distributed cell cycle time is equivalent to assuming that they all have a constant probability of dividing per unit time. This seems reasonable at first, but of course, it is false. Any cell that has just divided will have very small probability of dividing again too soon. That this actually makes a difference in the distribution of mutants in a population of a given size is seen clearly when considering the case of a population of four cells arising from a single ancestor. There are only two topologically distinct genealogical trees (Fig. 6.1) for the cells in this culture.

In the balanced tree (Fig. 6.1A), each of the four individuals has two divisions in their history and so has the same probability of being mutated: 2μ for μ small. In the second tree,

which is skewed (Fig. 6.1B), the four individuals went through 1,2,3 and 3 division events, with probability μ of mutating at each division, for a mean mutant frequency of $9/4\mu$. Also, there is clearly a larger variance compared to the balanced tree. To make the point even clearer, consider the polymerase-chain reaction. Here one starts with a small number, for simplicity say one, molecules of a nucleic acid, called template. By adding a polymerization enzyme, and energy-rich nucleotide monomers, the complementary strand will be synthesized for the initial template molecule. Then the complementary strands are dissociated from one another and the reaction is repeated for n cycles, to yield 2^n molecules of nucleic acid. At each cycle, all the molecules in the vat act as templates, and the complementary strand is synthesized for each of them. It is clear that only the completely balanced tree will be realized in this type of reaction. Theoretically, the probability of obtaining a given genealogical tree can be computed given the distribution of cell cycle times. The proportion of mutants in the final culture will depend only on the relative probabilities of realizing different types of genealogical trees with the same number of leaves, and on the probability of mutation at cell division. The problem is that this computation becomes intractable for even very small trees.

The approach that we eventually designed for accounting for the cell cycle time in the growth of the culture was suggested by our findings that:

- the mean proportion of mutants depends on the growth rate of the culture, and
- that the growth rate is only a function of the cell cycle parameters.

Analyzing the empirical distributions of mutants that we obtained for various cell cycle parameters, we found that they closely resemble in shape the Luria-Delbrück distribution. This prompted us to attempt to generalize a variant of the Luria-Delbrück distribution for cell-cycle time distributions other than exponential. This variant is a continuum approximation of L-D, due to my collaborator, T. Kepler (Kepler & Oprea, in preparation). In the next section, I present a brief outline of the derivation of this distribution.

6.4 Continuum approximation of the Luria-Delbrück distribution

The Luria-Delbrück distribution came out of a study designed to test whether mutations in a bacterial population subject to strong selection arise in response to the selective agent, or independently of it. The distribution of the number of mutants, M , in a culture of size N , that has been grown under conditions in which these mutations did not confer a selective advantage to the cells bearing them, came to be known as the Luria-Delbrück distribution. It constitutes the basis for mutation

rate estimation using the so-called "fluctuation analysis". Such an experiment involves growing a number of bacterial cultures from one cell to a final culture size N , and estimating the number of mutants in each of the parallel cultures. The mean or median number of mutants, or the proportion of cultures with no mutants are the statistics generally employed for mutation rate estimation. Fluctuation analysis has been applied to the study of mutational processes not only in prokaryotic, but also eukaryotic genomes (Jones et al., 1994). The mathematical study of the L-D distribution, initiated by Luria and Delbrück themselves, was elaborated by Lea and Coulson (1949); Bartlett (1978); Kendall (1948). More recently, a revisiting of the mutational processes in bacteria initiated by Cairns et al. (1988) caused another wave of mathematical exploration of the L-D distribution (Stewart et al., 1990; Sarkar, 1992; Jones et al., 1994). These efforts made the numerical computation of the L-D distribution reasonably efficient, though no closed form solution for it has been found.

In section 6.2, I described the basic setup for fluctuation analysis, which I used to construct my computational model. This setup is assumed in the derivation of L-D as well, with the restriction that at any moment, all replicators have equal probability of dividing. This can be shown to be equivalent of assuming an exponential distribution for the cell cycle time (recall that in my simulations I allowed for more general forms of the cell cycle time distribution). If we work in the regime where the product of mutation rate and culture size, μN , is large, but the product $\mu \log(N)$, giving the probability that any given cell is a mutant, is small, we can use the following approximation. Instead of taking the number of mutants, M as the random variable of interest, we take the proportion of mutants in the culture, $X \equiv M/N$, and approximate it as a continuous random variable. The validity of this approximation follows from the prior assumption $\mu N \gg 0$. We then determine the density function for X , and attempt to generalize this distribution for non-exponential cell-cycle time distributions.

We start from the generating function of the Luria-Delbrück distribution, defined as

$$g_N(s) \equiv E[s^M | N]. \quad (6.29)$$

Where $E[\cdot | N]$ is the conditional expectation. For L-D, this generating function was found by Bartlett:

$$\log g_N(s) = \frac{\mu N(1-s)}{s} \log\left(1 - s\left(1 - \frac{N_0}{N}\right)\right), \quad (6.30)$$

with μ being the mutation rate per cell per division, N_0 the initial number of cells and N the final number of cells in the culture. Retrieving the probability distribution from the generating function is non-trivial, and much of recent work has been focussed on ways of producing efficient means for doing so in the absence of closed-form solutions. It turns out that, if we work in the continuum

limit, we can derive an integral form of the distribution. Stated formally, the conditions that need to be fulfilled for the continuum approximation to hold are:

$$\mu(N - N_0) \gg 0 \tag{6.31}$$

and

$$\mu \log(N/N_0) \ll 1. \tag{6.32}$$

The continuum version of L-D will be designated cLD. The characteristic function of cLD is obtained from the generating function by substituting $s = e^{-iz}$. This being the Fourier transform of the density function, one could use the Fourier theorem to recover the probability distribution, $p(x)$:

$$p(x) = \frac{1}{2\pi} \int_{-\infty}^{+\infty} g(e^{-iz/N}|N)e^{ixz} dz \tag{6.33}$$

Through complex integration, and a change of variable, one arrives at an integral form in terms of a scaled variable

$$\xi = \frac{x}{\mu} - \frac{1}{\beta}, \tag{6.34}$$

where x is the proportion of mutants and $\beta = \mu N$. The distribution of ξ is given by:

$$p(\xi) = \frac{1}{\pi} \int_0^{\beta-\epsilon} \left(\frac{\beta - \epsilon - w}{w} \right)^{w+\epsilon} \left(1 - \frac{w + \epsilon}{\beta} \right)^{\beta\xi} \sin(\pi(w + \epsilon)) dw, \tag{6.35}$$

where $\epsilon = \mu N_0$. This integral form can be used directly to retrieve the cLD distribution.

6.4.1 Cell-cycle correction to the continuum Luria-Delbrück distribution for 2-phase models of the cell cycle

Recall that cLD is obtained starting from the Bartlett generating function, which is the generating function corresponding to the Luria-Delbrück distribution. Also recall that the mean proportion of mutants can be expressed as $c\mu \log(N)$, where the correction factor c only depends on cell cycle parameters. We may view $c\mu$ in this formula as the *effective* mutation rate. This observation prompted us to attempt to generalize cLD for non-exponential distributions of cell cycle times. The approach is essentially to replace μ by the *effective* mutation rate $c\mu$. It turns out that, for cell cycle times that are distributed as a shifted exponential, this is not sufficient to give us mutant distributions that fit the experimental ones. However, if we also assume that the effective number of initial (and final) number of cells in the culture is $(b/c)N_0$ (and $(b/c)N$), we can obtain very good fit between the simulation data and the theoretical prediction. Note that here I grouped together the correction factor for the mutation rate and the correction factor for the number of cells in one parameter b . For the correction factor for the mutation rate we have an analytical expression. The

correction factor for the cell number we have to determine by fitting the simulation data to the generalized form of cLD.

I will describe the fitting procedure for the parameter b . It turns out that the value of this parameter is determined by the ratio r of the division time (T_B) to the mean waiting time ($1/\lambda$). It is not affected by the mutation rate or the final number of cells in the culture. The major implication of this result is that we can obtain the value of this parameter for any r of interest by simulating cultures with relatively small numbers of cells. We can then use this value for any culture size, and thus infer mutation rates in realistic-size cultures.

In the integral form of the distribution, we let $\beta = b\mu N$ and $\epsilon = b\mu N_0$. The scaled variable ξ becomes

$$\xi = \frac{x}{c\mu} - \frac{1}{b\mu N}. \quad (6.36)$$

We then perform a one-parameter optimization, using as criterion for the goodness of fit the χ^2 value. The procedure is the following. We generate the empirical distribution of the proportion of mutants (and the corresponding cumulative distribution) from the simulation data. This will also give us the distribution of the variable ξ , which is related to the proportion of mutants, x , through Eq. 6.36. c is the correction factor due to the cell cycle time distribution (Eq. 6.28), N is the final number of cells in the culture, μ is the mutation rate that we used in the simulation, and b is the parameter that we need to identify. We may use as a first choice for b its value for the L-D distribution, which is 2. Let $D(\xi)$ denote the empirical cumulative distribution of ξ . Let $T(\xi)$ be the theoretical cumulative distribution of this variable. We can calculate this distribution using the integral form of Eq. 6.35, with parameters $\beta = b\mu N$, and $\epsilon = b\mu N_0$. The quantity that we want to minimize is the χ^2 value, calculated as:

$$\chi^2 = \frac{1}{N} \sum_{\xi} \frac{(D(\xi) - T(\xi))^2}{T(\xi)}. \quad (6.37)$$

where ξ takes values as given by Eq. 6.34, with the proportion of mutants varying between 0 and 1, in increments of $1/N$. In fact, we neglected the cumulative density values below 0.01 and beyond 0.99 (in a few cases 0.98 or 0.97). They do not affect the fit significantly, while the computation of the integral becomes difficult in these regions. Also, the simulation data is less precise in these regions, as we would need a very large number of runs to be able to see events that have a very low probability. We find that value of the parameter b that minimizes the χ^2 value. The algorithm for minimization is the Golden Section Search algorithm, described in Press et al. (1988). Table 6.4.1 gives these values for a number of data sets. Note that N_0 , N , and μ are the values that we used in the simulations. $(b/c)N_0$, $(b/c)N$, and $c\mu$ are the *effective* initial number of cells, final number of cells, and mutation rate. The cases where we truncated the right-hand tail at proportions different

from 0.99 are marked.

Table 6.3: Fit of the b parameter. Right tails truncated at 0.99, unless otherwise specified (0.98 marked by †, 0.97 by ‡)

N_0	N	μ	r	b	χ^2
1	10^4	10^{-3}	0	1.979	0.000263
1	10^5	10^{-4}	0	2.003	0.000427
1	10^5	10^{-3}	0	1.974	0.000911
1	10^4	3×10^{-4}	1	2.695	0.007509
1	10^4	10^{-3}	1	2.769	0.003966
1	10^4	3×10^{-3}	1	2.749	0.000905
1	10^5	10^{-4}	1	2.821	0.00126
1	10^5	3×10^{-4}	1	2.824	0.00112
1	10^5	10^{-3}	1	2.771	0.00335†
1	10^4	3×10^{-4}	3	2.889	0.00702
1	10^4	10^{-3}	3	2.979	0.00617
1	10^4	3×10^{-3}	3	2.955	0.00159
1	10^5	10^{-4}	3	3.037	0.00272
1	10^5	3×10^{-4}	3	3.076	0.000514
1	10^5	10^{-3}	3	3.016	0.00202‡
1	10^4	3×10^{-4}	9	2.949	0.00743
1	10^4	10^{-3}	9	3.062	0.00565
1	10^4	3×10^{-3}	9	2.988	0.00991
1	10^5	10^{-4}	9	3.022	0.00379
1	10^5	3×10^{-4}	9	3.163	0.00576
1	10^5	10^{-3}	9	3.081	0.00587‡

The first three data sets in the table correspond to cultures based on exponential cell-cycle time distribution. As we expect, the value of the parameter b for all these data sets is around 2. As the division time T_B becomes a larger proportion of the cell cycle, the value of the parameter b increases. However, the most dramatic change occurs when T_B changes from being negligible, to being as large as the mean waiting time. The other parameter of these distributions, c , shows a similar behavior. The effective mutation rate is maximal for $T_B = 0$, it decreases with r , with the most dramatic change occurring at the transition between $r = 0$ and $r = 1$.

6.4.2 Inference procedures.

I will outline the procedure that we can use for constructing confidence intervals for the mutation rate using the parameterized distribution that I described in the previous section.

Assume that we start with a datum x , representing the proportion of mutants in the culture, and the we know parameter r of the cell cycle time distribution. Knowing r , we can first calculate the growth rate of the culture, using Eq. 6.27 determine, with $T_B = r/(r + 1)$ and $\lambda = r + 1$. We

then calculate c , the correction for the mutation rate, by the formula 6.28. We retrieve the value of the parameter b from Table 6.4.1. We can calculate the value of the scaled variable as a function of the mutation rate

$$\xi(\mu) = \frac{x}{c\mu} - \frac{1}{b\mu N}. \quad (6.38)$$

Assume that we want to find the $1 - a$ confidence interval for the mean. All we need to do is to find the values of the mutation rate for which the given datum $\xi(\mu)$ corresponds to the $a/2$ and $1 - a/2$ quantiles, respectively, of the distribution specified by the formula 6.35. As the quantile to which x corresponds is a monotonic function of μ , a simple search algorithm on μ would give us these values.

This procedure can be easily automated. The interface to it would be simple, the query being specified by only two variables: the ratio r of the division time to the mean waiting time (or, even simpler, the coefficient of variation of the cell cycle time), and the observed proportion of mutants in the culture. The program would construct confidence intervals for the mutation rate. I believe that this approach would provide a very useful tool in the study of mutational processes.

6.5 Constructing confidence intervals for the mean mutation rate in cultures of cells that have a gamma-distributed cell cycle time

Mutant distributions in cultures in which the cells have a gamma-distributed cell cycle time are not amenable to the same type of parameterization that I described in section 6.4.1. Thus, at the moment we do not have an expression for these distributions that we could use in estimating the mutation rate using the above method. We have, however, explored the behavior of the mutant distributions that we obtain from our simulations. We found some properties that allow us to construct a confidence interval based on the observed mean proportion of mutants. The approach is the following.

We construct the mutant distribution empirically, through simulation. The limiting factors are the running time and the memory taken up by the cell objects. Constructing a culture of size N requires $N - 1$ division events. The problem for large culture sizes is two-fold. Not only does it take longer to simulate the culture growth, but also the number of independent runs that we would have to do to obtain an accurate distribution becomes larger.¹ Cultures of size $10^4 - 10^5$ can,

¹Using a Sun Ultra2 2300, 300 MHz processor, running SunOS 5.5.1, one run of 10^5 cells takes 8 seconds and 3.7MB RAM. The complexity of the algorithm is $O(N \log(N))$, as it amounts to constructing the priority queue of cell objects. However, we have to do of the order N runs to obtain the distribution, thus the complexity of the algorithm

nonetheless, be simulated on the currently available workstations. Thus, for the germinal center reaction, in which the number of cells does not surpass 2×10^4 , we can still simulate the growth of the cell population.

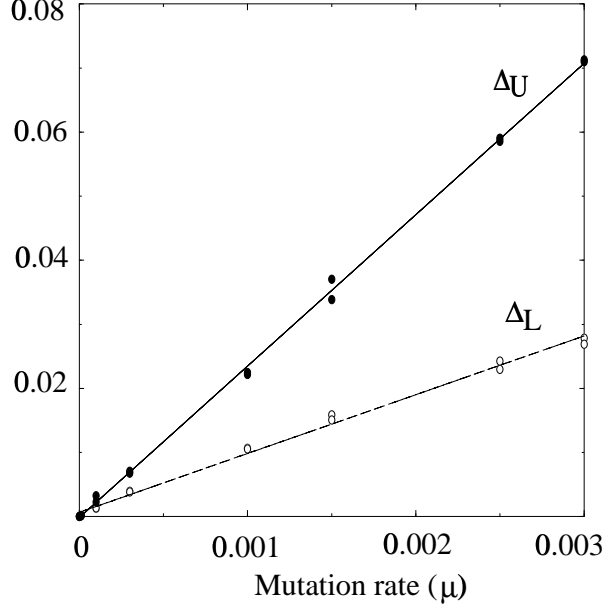

Figure 6.2: Δ_U (closed circles) and Δ_L (open circles) as a function of the mutation rate for a gamma-distribution of order $q = 10$. Both data sets for culture size $N = 10^4$ and $N = 10^5$ are represented. Linear fits to these values are represented in solid (for Δ_U) and dashed (for Δ_L) lines.

As I mentioned before, when the cell cycle time is gamma-distributed, only the order parameter of the gamma distribution determines the relative probability of realizing different genealogical trees. I denoted this parameter by q . For a given q , I generated 10^4 independent runs for each value of N (either 10^4 or 10^5 cells) and each value of the mutation rate. I then investigated the behavior of the quantiles of the distribution of the proportion of mutants. Let $x_{0.05}$ and $x_{0.95}$ denote the 5 and 95 quantiles, respectively, and \bar{x} the mean proportion of mutants. It turns out that the quantities $\Delta_L = \bar{x} - x_{0.05}$ and $\Delta_U = \bar{x} - x_{0.95}$ are quite similar for the two values of N . Furthermore, they are well approximated by linear functions of μ , for a given order of the cell-cycle time distribution, q . The information on the linear regression is given in Table 6.4. *How do we use these findings to construct the $1 - \alpha$ confidence interval for the mutation rate?* If we write our linear fits as

$$\Delta_U(\mu) = \delta_U \mu + O(\mu^2) \tag{6.39}$$

$$\Delta_L(\mu) = \delta_L \mu + O(\mu^2) \tag{6.40}$$

for constructing the distribution is at least $O(N^2 \log(N))$.

Table 6.4: Linear regression of Δ_L and Δ_U as functions of the mutation probability.

Variable	Slope(S.E.)	Intercept(S.E.)	Correlation coefficient
Δ_L	9.181502 (0.1760939)	0.0006655711 (0.0002685078)	0.997435
Δ_U	23.63253 (0.1867707)	-0.0001423919 (0.0002847877)	0.9995631

then the $1 - a$ confidence interval on μ is given approximately by the bounds

$$\mu_L = \frac{x}{c \log(N) + \delta_U} \quad (6.41)$$

and

$$\mu_U = \frac{x}{c \log(N) - \delta_L}, \quad (6.42)$$

where x is the observed proportion of mutants in the culture and c is the correction factor for the mean, given by the cell cycle parameters.

6.6 Estimating mutation rates in real cultures

6.6.1 Bacterial growth

I will return now to the question of mutation rate estimation in bacterial cultures. Luria-Delbrück fluctuation analysis is generally used to estimate the rate of so-called growth-dependent mutations in bacterial cultures. These are to be distinguished from adaptive mutations that occur in slowly growing cultures, in which little cell division takes place (Torkelson et al., 1997). The distinction seems to be mostly in terms of the mutational mechanism. In the first case, the spectrum of observed genetic changes seems to be much more heterogeneous, and thus believed to occur via multiple mechanisms, whereas adaptive mutations are similar in various cells or systems, and have been related to recD gene activity.

Restricting ourselves to mutations that occur in growing cultures, we saw that the assumption that underlies the L-D distribution of mutants, namely that the cell cycle time is exponentially distributed, results in underestimation of the mutation rate. In the above sections I provided improved methods that take into account the cell-cycle time distribution. There are a number of other sources of errors that I would like to briefly discuss here.

In my simulations, I can precisely count the mutants when the culture reaches size N . In fluctuation analysis experiments, one cannot decide individually for each cell whether its phenotype is wildtype or mutant. The number of mutants is estimated by taking a sample of the culture, growing it on a selective environment, that only supports the growth of the mutants, and counting

the number of colonies. Each colony is assumed to have been seeded by one mutant cell. Jones et al. (1994) discusses to a large extent the statistical complications associated with estimating the number of mutants in the culture. One issue which is not addressed in their study, is the assumption that the cells were in exponential growth over the whole period of the experiment. Such a condition is difficult to ensure. After growing exponentially, a bacterial culture generally experiences significant cell death, after which a stationary phase settles in. Although I will not go into the details of correcting for the cell death at the end of the exponential phase, as this would require detailed knowledge of the mechanisms involved, I will outline the procedure for a simple case. The basic assumption would be that death affects with equal probability wildtype and mutant cells. Then what we need to know in order to infer the mutation rate is the cell-cycle time distribution, and the counts of viable and dead cells at the time of mutant detection. The distribution of mutants in the final culture can be obtained from the convolution of the distribution at the end of exponential expansion and the hypergeometric distribution, corresponding to the sampling realized by the death process. That is, if mutants and wildtype cells are equally likely to be affected by death, the set of viable cells is essentially a sample, without replacement, of the cells at the end of the phase of exponential growth.

I believe that at this moment we have the basic components for an accurate method for mutation rate estimation in bacterial cultures. Automating this method is one of my topics of future work.

6.6.2 Emergence of high affinity mutants in the germinal centers

Our initial motivation for improving mutation rate estimation techniques was to estimate mutation rates in germinal centers. Compared to the simple computational model that I designed for a bacterial culture, the cell population dynamics in the germinal centers is complicated by a number of factors:

- Germinal centers have an initial phase of exponential expansion of cells, which is followed by an apparent steady-state in cell number. During this phase there is considerable cell death, as well as clonal expansion.
- Cells grow in a selective environment. Certain mutations are advantageous, and of these, some result in preferential expansion of the clone (Radmacher et al., 1998). At the moment we have no quantification of the selective advantage of these clones, and we do not know by what mechanism their rapid expansion occurs.

- Deleterious mutations can also be generated, and they seem to be relatively rapidly followed by the death of the cell.

These constraints make it extremely difficult to attempt an accurate estimate of the mutation rate in germinal centers. An approach that is used experimentally in order to circumvent the selection problem, is to look at passenger genes in B cells that went through a somatic mutation process. A passenger gene is a gene that does not affect the survival probability of the cell in a particular environment. In our case, this environment is the germinal center. The claim is that the association of the passenger gene with a successful or unsuccessful phenotype, that is, with a high or low affinity immunoglobulin receptor is irrelevant. If we focus on one site (nucleotide position) of the passenger gene, the mutant distribution only depends on the relative probability of generating different tree shapes (and, of course, on the probability of mutation per cell replication, assuming that mutations are replication-dependent). This is what we found in the analysis of the L-D distribution. If the association between the passenger gene and a successful or unsuccessful phenotype were relevant, then the relative probabilities of different trees would have to be modified by this association. It is conceivable that successful mutants are selected faster and/or divide at faster rates than unsuccessful ones. Then if the cell harbors a successful mutation, its cell cycle time may have a different distribution than if the cell did not have this mutation. If this were the case, the number of generations that a cell goes through would depend on its selected receptor. Thus, it is not clear that measuring the mutation rate from passenger genes that are carried by cells that have functional, selected receptors, circumvents the selection problem.

However, looking at this experiment differently allows me to design a mutation rate estimation method based on passenger gene mutation. Let us assume that up to the point when the successful mutant appeared in the germinal center, the cells underwent exponential expansion, with cells cycle times being independent, identically-distributed random variables. The consistency of the estimate of the waiting time for a successful mutant (Radmacher et al., 1998) and of the duration of the exponential expansion phase of the germinal center reaction (Liu et al., 1991) support this hypothesis. Let us further assume, similar to Radmacher et al. (1998), that the progeny of this successful mutant will take over the germinal center.

Now consider the germinal center cells at the end of germinal center reaction. Sequencing their passenger gene and taking the intersection of the mutation sets in these genes, we should obtain the set of mutations that were present in the founder cell of the clone that stumbled upon the successful mutation. So the set of mutations in the passenger gene of this founder gives us an estimation of the number of mutations in a cell at the end of the exponential expansion phase.

I will now define the quantities that I need for estimating the mutation rate from these data:

- $P(g|N)$ = probability that a cell in a culture of size N is of generation g . I will assume that the generation number of the cell that finds the key mutation when the culture reached size N is the average generation number in the culture at that time. To be accurate, we would have to exclude the cells in the culture whose sister cells divided already. They cannot be recently born, and the mutation can only be in a recently born cell. This density function is completely determined by the cell cycle parameters, and I can determine it by simulation.
- $P_\mu(N)$ = probability that the genealogical tree of the culture is of size N when the successful mutation is found. A tree of size N is generated by $N - 1$ divisions. With a constant mutation rate per division, the probability of finding the successful mutant will only be related to the tree size, not to the tree shape. Specifically, let us assume that the successful mutant is only one mutation away from the germline. Let μ be the probability of a mutation per site per division. Let p be the probability that a mutation at the site of interest produces the appropriate nucleotide (I will assume for the moment that all nucleotides have an equal chance of being produced by a mutation). Then the probability that the mutation occurred at the $N - 1^{st}$ division is

$$P_\mu(N) = (1 - \mu p)^{N-2} \mu p.$$

Note that I neglect here the deleterious mutations that might have been generated at other sites before the successful mutant was found. We may relax this assumption, and use an effective mutation rate, which would be weighted by the probability that a mutation is lethal. Also, given the results of Radmacher et al. (1998), I would have to weight the mutation rate by the probability that the high-affinity mutation seeds the clone that takes over the germinal center.

- $P_\mu(g)$ = probability that the successful mutation is found in a cell of generation g .

$$P_\mu(g) = \sum_{N=1}^{\infty} P_\mu(N) P(g|N).$$

- $P_\mu(m)$ = probability of m mutations in the passenger gene. Consider one nucleotide position in the passenger gene. Its probability of mutating in one division is μ . Note that here I take the probability of a mutation per site per division, not the probability of a specific substitution, as I did when I determined the probability of producing the successful mutant. $(1 - \mu)^g$ is the probability of no mutation in g generations, and $1 - (1 - \mu)^g$ is the probability of at least one mutation in g generations. Then if the passenger gene is L nucleotides long, the probability of

m of them being mutated is given by

$$P_\mu(m) = \sum_{g=1}^{\infty} P_\mu(g) \binom{L}{m} [(1-\mu)^g]^{L-m} [1 - (1-\mu)^g]^m.$$

The estimation procedure would then be as follows. We take passenger sequence data from a number of cells from a number of germinal centers. For each set of sequences that comes from the same germinal center, we take the intersection of the mutation sets of individual sequences. This gives us the set of mutations present in the founder of that particular germinal center. We determine $P(g|N)$ for our experimental system, using a reasonable cell-cycle time distribution. and germinal center size. We know the lengths of the genes, and we can generate a family of curves of mutation frequency distribution as a function of the mutation rate. We can then identify the mutation rate that gives the best fitting curve for the passenger gene mutation frequency.

Chapter 7

Conclusions

I would like now to review the questions that I addressed in my dissertation and summarize what I learned from the experiments that I constructed.

The immune system is viewed as a detection system. It detects pathogenic intrusions. In contrast to the familiar detection systems though, the immune system can recognize pathogens that the organism may have never encountered before in its life time. This ability derives, to a certain extent, from the generality of the language of biochemistry. A variety of immune receptors are generated without regard to what they may be binding. Those that react strongly with molecules that are normally present in the body are weeded out, and those that remain will, by definition, recognize "outsider" molecules. However, the immune system has only a limited number of cells that circulate at any time through the body. It is therefore crucial that the immune system makes optimal use of its resources by placing the receptors "strategically" in the space of all possible receptors. Having the right type of lymphocytes in the right number is crucial for the survival of the organism.

The questions that I addressed in my thesis are related to how the immune system might learn to anticipate its pathogenic environment. Based on the results that I summarize below, I argue that:

- The recognition capacity of the immune system is targeted to pathogens that it has encountered during evolution. It does not attempt to recognize as many molecular shapes as possible.
- Germline diversity does not contribute to the direct, specific recognition of pathogens, but rather realizes a coarse-grained coverage of the pathogen space.
- Immune receptor diversification during an on-going immune response is the determinant factor for the specificity and affinity of the antibodies. If the immune system fails to recognize a

pathogen with high affinity, it means that:

- the pathogen mimics the self structures too closely, or
- the pathogen is an emergent pathogen, considerably different from those that the immune system has seen during its recent evolution, or
- somatic hypermutation fails to produce a high affinity antibody for that pathogen, due probably to sequence peculiarities of the germline-encoded antibody that underwent somatic hypermutation.

My detailed results also bear on the construction of random antibody libraries, as well as on computational methods that may be used for mutational analysis in a variety of biological systems.

Note that I did not consider the effect of junctional diversity on the repertoire. The reasons are as follows:

- I focused on the aspects of evolutionary learning in the immune system. The rearrangement process is essentially thought to produce "random" junctions. It could thus not be the substrate for learning.
- If the rearrangement process indeed produces "random" junctions, then its contribution to the repertoire is to increase the size of the primary repertoire. However, if this repertoire cannot cover pathogens individually, then the results that I presented based on a single library are expected to hold.

7.1 Summary of results

7.1.1 Germline diversity does not contribute to the direct recognition of pathogens

In chapter 2 I used a simple model of gene library evolution to investigate the scaling of the survival probability of an organism with the number of antibodies in its repertoire. I showed that for distributions of the antibody-antigen bond strength that I consider of biological relevance, the survival probability of the organism increases logarithmically, or sublogarithmically, with the size of its germline-encoded antibody repertoire. This suggests that the role of germline-encoded immune receptor genes is not specific recognition of individual pathogens, but rather a coarse-grain encoding of the region of the pathogen universe that the species has encountered in evolution. I showed that such an encoding can be achieved if an individual is confronted with a large fraction of the possible pathogens in its life time. High-affinity recognition of a pathogen would then have to be achieved

through fine-tuning of the antigen receptor during an immune response. If the number of pathogens that the organism encounters is comparable with the number of receptors that it can encode in germline, then a static pathogenic environment would result in better learning of the training set. However, if the pathogenic environment changes, the performance of the immune system would be lower on the pathogens that it encountered, but it would be higher on random pathogens. The reason for this behavior, which one might view as robustness, is that, although static pathogenic environments result in specialized libraries, dynamic pathogenic environments induce essentially random antibody libraries.

7.1.2 Immunoglobulin genes evolved plasticity for somatic hypermutation

The basic mechanism that is responsible for fine-tuning of antigen receptors has been described. It is termed affinity maturation, and it involves rounds of essentially random mutagenesis followed by selection. In chapter 3, I introduced a new method for analyzing the plasticity of individual immunoglobulin genes under somatic hypermutation. I showed that codon bias consistent with low framework, and high complementarity-determining region, mutability is found in individual *V* region genes in a variety of species. I also showed that the codon composition of the genes is a good predictor of their mutability. The methods that I introduced in this chapter can be applied both to the analysis of individual gene sequences, as well to sets of genes. These are both important issues. In somatic hypermutation experiments there is always the question of the intrinsic mutability of the gene relative to selection pressures that operate on the protein product. Also, the study of the immunoglobulin gene family is generally difficult due to the close genealogical relationship between these genes. These problems are explicitly addressed in the tests that I designed. I further analyzed the sequence specificity of the somatic hypermutation mechanism by applying it to a set of non-immunoglobulin genes. Intriguingly, I found that these genes have a codon bias consistent with low mutability under somatic hypermutation as well. This result suggests a possible connection between the somatic hypermutation mechanism and more general processes that operate throughout the genome. I provided further supporting evidence, by showing that the somatic hypermutation mechanism reveals the A/T content of the gene. That the evolutionary stability of A/T-rich nucleic acids, and the proteins they encode, is lower than their G/C-rich counterparts has already been shown, though the factors that may be responsible for it are debated.

7.1.3 The efficiency of affinity maturation can only be explained by multiple rounds of mutation-selection-expansion of lymphocytes

The germinal center reaction is generally described as a one-pass process, with B cells coming into the germinal center, undergoing division and somatic mutation in one compartment, then moving into another compartment for selection, and finally leaving the germinal center. There have been a number of studies showing that a large number of high affinity mutants can be produced more efficiently if cells were to cycle between the selection compartment and the reproduction compartment. In chapter 5 I showed quantitatively that the one-pass scenario is incompatible with the observed efficiency of affinity maturation. I also showed that the decay of the selective agent (antigen) reduces the efficiency of amplification of high-affinity cells from linear to logarithmic in their selective advantage. This gives even more theoretical support to the recycling hypothesis. It also provides useful insights into processes in which selection is due to an agent that decays in time.

7.1.4 Improved methods for mutation rate estimation

In trying to understand the mechanism responsible for somatic hypermutation, one often encounters the problem of accurately estimating the mutation rate. The currently employed method is based on the fluctuation analysis experiment of Luria and Delbrück (1943). While attempting to adapt this method to mutation rate estimation in germinal centers, I found that, due to implicit assumptions about the cell-cycle time distribution, this method underestimates the mutation rate by as much as 30%. In chapter 6, I introduced a number of methods for estimating mutation rates and constructing confidence intervals, each of which takes into consideration the cell-cycle time distribution. I gave cell-cycle corrections for the mean proportion of mutants in the culture for two of the most common models of cell cycle time. The derivation can be used for other cell cycle time distributions as well. I described a continuum approximation for the Luria-Delbrück distribution, that is considerably easier to use than the currently available methods. I also give a parametrization of this distribution that can be used for cell cultures of arbitrary size, provided that the cell cycle time obeys a shifted exponential distribution. Gamma-distributed cell cycle times do not allow a similar parametrization of cLD. However, I found that the 5% and 95% of the proportion of mutants scale linearly with the mutation rate. Moreover, the slope of these curves does not seem to be sensitive to the culture size. These findings allowed me to design a method for constructing confidence intervals for the mutation rate in this types of cell cultures as well. Finally, I discuss extensions of the above methods for cultures that reach steady-state, as well as for germinal centers. Given that they readily lend themselves to automatization, I believe that the methods that I introduced in this chapter have the

potential of becoming widely adopted in the field of experimental biology.

7.2 Future work

I think I have reached an understanding of the role of germline diversity and somatic mutation in generating the immune repertoire. However, there still are a number of related problems that I am currently working on, or hope to be working on in the near future. The most concrete project concerns implementing the mutation rate estimation methods that I only introduced conceptually in my dissertation. There are other issues that could be pursued, based on the work that I presented here. We parametrized the Luria-Delbrück distribution using a parameter that we determined empirically, by fitting to simulation data. We do not have an analytical form for this parameter. It would be of great interest to find that form. Moreover, for the case of gamma-distributed cell cycle times, we do not have as much as a distribution based on an empirically-determined parameter.

The finding that non-immunoglobulin sequences share optimization features with respect to somatic hypermutation raises the exciting possibility that somatic hypermutation is derived from more general mutation mechanisms that operate across the genome. What the nature of these mechanisms might be has not been revealed by my analyses. I have, however, a starting point for that search. That is the observation that somatic mutation targets A/T nucleotides. The next step is to look into what mutation/repair mechanisms might share such a bias. One candidate is the single-base mismatch repair that seem to preserve G nucleotides (Bill et al., 1998). I also intend to determine the sequence specificity of the germline mutation mechanism and compare it directly to the specificity of somatic hypermutation.

In my analysis of the properties of the germline-encoded repertoire, I concluded that "sticky" antibodies are a good anticipative strategy. Antibodies of this type indeed have been described, especially in neonatal immune systems. However, they pose the problem that they bind not only pathogens, but also self structures. We could now introduce a set of self molecules and require that the repertoire not bind these molecules. It would be very interesting to find out what type of antibodies would emerge under these conditions.

Finally, there are processes which take place at the gene level, that might constrain the learning capacity of the immune system. These have not been not been taken into account by the models that I described in this dissertation. They are, however, important issues to consider if one is to understand the dynamics of the immune repertoire. The generation of the antibody repertoire in neonates seems to be much more deterministic than in adults. This justified, in part, my analysis of the "germline-encoded" antibodies. These antibodies are characterized by the lack of non-templated

nucleotide additions, and by preferential V-D, D-J, and V-J associations. It is believed that short regions of homology at the ends of the rearranging fragments are responsible for constraining the rearrangement process. I intend to build a mechanistic model for the rearrangement process, which I can use to test the previous hypothesis.

Gene conversion introduces a sampling dynamics at the level of genes. It would be interesting to know how much germline diversity can be maintained with reasonable values of the parameters that determine the dynamics of gene conversion. In certain species, such as chicken and rabbit, gene conversion is used as a primary diversification mechanism, responsible for creating the naive repertoire. The donor genes are generally pseudo-genes, that is they cannot, by themselves, generate functional immunoglobulins. It would be interesting to know what type of dynamics these genes have, given that they are constrained by the interaction with the acceptor gene. The mechanism of gene conversion is also not known. Using gene conversion data, one could attempt to infer what this mechanism might be, in a way that would be similar to my attempt to infer the nature of the somatic hypermutation mechanism.

7.3 In lieu of closing

As can be inferred from the previous section, the topics that I explored in my dissertation are far from being exhausted. In fact, it seems that I have only managed to scratch the surface. Or, the way I think about it, to set the stage for a more rigorous understanding of these processes. As of what I will be remembered by...

Appendix A

Non-immunoglobulin genes

Protein	Accession Code
C reactive protein	HUMCRPG
Mannose-binding protein associated serine protease	HUMMASP
Serum amyloid A	HUMSSAB
LPS-binding protein CAP18	HSU19970
Fas ligand	HUMHPC
Fas antigen	HUMFASANT
Cysteine protease ICE-LAP3	HSU39613
Thromboxane synthase	HUMTBSB
liver-type 1-phosphofructokinase	HSPFKLA
Glycerol-3-phosphate dehydrogenase	HSU12424
Glyceraldehyde-3-phosphate dehydrogenase	HUMG3PDB
Pyruvate kinase	HUMPVK
Ubiquinol-cytochrome C reductase	D55636
2,4-dienoyl-CoA reductase	HSU49352
Mitochondrial NADH-ubiquinone reductase	HUMMTNUBA
Dihydrofolate reductase	HUMFOLMES
Steroid 5-alpha-reductase	HUM5AR

Protein	Accession Code
Histone H1	HSHIS10G
Histone H2A	HSHISH2A
Histone H2B	HSHISH2B
Histone H4	HSHISH4
Heat shock protein (hsp 70)	HUMHSP70D
Heat shock protein (hsp 27)	HSHSP27
Heat shock protein (hsp 90)	HUMHSP90B
Heat shock protein (hsp 40)	HUMHSP40
Prostaglandin D synthase	HUMPROSYN
Methionine synthase reductase	AF025794
Nitric oxide synthase	HUMNOSA
PAPS synthase	HSU53447
Phosphatidylinositol synthase	AF014807
Prostacyclin synthase	HUMPTGIS
Glycogen synthase	HUMHLGS
Hyaluronan synthase	HUMHAS
UMP synthase	HUMUMPS
CDP-diacylglycerol synthase	HSU60808
UDP-galactose ceramide galactosyl transferase	HSU30930
Ganglioside-specific alpha-2,8-polysialyltransferase	HUMGD3G
Lanosterol synthase	HUMLASY
Spermidine synthase	HUMSPERSYO
Uroporphyrinogen III synthase	HUMRODSA
Hydroxymethylbilane synthase	HSPBGDR2
Farnesyl pyrophosphate synthetase	HUMFAPS
6-pyruvoyltetrahydropterin synthase	HUM6PTHS
Ubiquinone-binding protein	HSUBPQPC

Protein	Accession Code
Cytochrome C oxidase subunit Va	HUMCOXNE
Alpha-keto acid dehydrogenase transacylase	HUME2B
Mitochondrial matrix protein	HUMPMMP1
ATPase coupling factor 6 subunit	HUMATPSY
Carbonic anhydrase	HUMCARBANH
NADH:ubiquinone oxyreductase B12 subunit	AF035839
Sodium-hydrogen exchanger 6	AF030409
Malate dehydrogenase precursor	AF047470
Ornithine transcarbamylase	HUMOTC
Nicotinamid nucleotide transhydrogenase	HSU40490
Mitochondrial DNA polymerase accessory subunit precursor	HSU94703
Fumarase precursor	HSU59309
Mitochondrial RNA polymerase	HSU75370
Carnitine palmitoyltransferase I	HSU62733
Uncoupling protein 2	HSU76367
Thioredoxin	HSU78678
Citrate transporter protein	HSU25147
Pyruvate carboxylase precursor	HSU30891
Sarcomeric mitochondrial creatine kinase	HUMSMCK
ATP synthase subunit 9	HSU09813
Integral membrane protein CII-3	HSU57877
NADH dehydrogenase ubiquinone Fe-S protein	HSU65579
Bcl-2 binding protein Nip3	AF002697
Voltage-dependent anion channel isoform 2	HUMVDAC2X
Mitochondrial ssDNA-binding protein	HUMMTSSB
ATPase F1 beta	HUMF1B
Platelet membrane glycoprotein V	HUMGLYCOPR

Protein	Accession Code
Serine esterase	HUMCSE
Granulocyte/macrophage colony-stimulating factor	M11734
1,2-cyclic-inositol-phosphate phosphodiesterase	HUMANX3
Alpha enolase	HUMENOA
3-hydroxy-3-methylglutaryl coenzyme A reductase	HUMHMGCOA
Myelin proteolipid protein	HUMMBPZ
Thrombomodulin	HUMTHMA
Extracellular superoxide dismutase	HUMSODEC
Farnesyltransferase alpha	HUMFTA
Farnesyltransferase beta	HUMFTB
Prepro-8-arginine-vasopressin-neurophysin II	HUMVPPNP
Uroporphyrinogen decarboxylase	HSU30787
Transcription activator STAT5B	HSU47686
Fibroblast growth factor receptor	HSFGFR
Lactoferrin	HSLTFRG
Vimentin	HSVIMENT
Sialyltransferase	HSSIATR
Tryptophan hydroxylase	HSWHYDR
Multispecific organic anion transporter	HSU63970
9-cis-retinol specific dehydrogenase	HSU89717
Threonine kinase	AF035625
Splicing factor Sip1	AF030234
Zinc finger protein (ZNF198)	AF012126
Voltage-dependent potassium channel	HUMVENHK1
Citrate synthase	AF047042
Retinoic acid hydroxylase	AF005418
Lanosterol 14-demethylase	HUML14D

Protein	Accession Code
Cytochrome P450 monooxygenase CYP2J2	HSU37143
Alcohol dehydrogenase beta 1	HUMADH21C
Lymphocyte dihydropyrimidine dehydrogenase	HSU20938
Microsomal aldehyde dehydrogenase	HSU46689
Pyruvate dehydrogenase kinase isoenzyme 1	HUMPDK1R
Xanthine dehydrogenase/oxydase	HSU39487
Succinate dehydrogenase iron-protein subunit	HSU17248
Potassium channel	HUMPCC
Histone acetyltransferase	AF030424
Histone stem-loop binding protein	U75679
Nuclear receptor coactivator	AF036892
TFIID subunit	HSU57693
Histone deacetylase HD1	HSU50079
Centromere protein A	HSU14518
Inositol 1,4,5-triphosphate 3-kinase	HSHIP3K
Histone decarboxylase	HSHISDEC
Methionine synthase	HSU73338
Dolichol-phosphate-mannose synthase	D86198
Glutathione-requiring prostaglandin D synthase	D82073
Nonhepatic arginase	D86724
Spermidine aminopropyltransferase	HUMSAPT
Ceramide glucosyltransferase	HUMCGA
Protein kinase	HUMGLSYKIN
Glutathione S-transferase	HSU12472
Guanosine 5'-monophosphate synthase	HSU10860
Leukotriene-C4 synthase	HSU11552
Squalene synthase	HUMSQUAL

Protein	Accession Code
Prostaglandin endoperoxide synthase	HUMPGES
Cytochrome C oxidase assembly protein COX11	AF044321
Glutathione transferase Zeta 1	HSU86529
Glutathione S-transferase 3	AF026977
O-linked GlcNAc transferase	HSU77413
Succinyl CoA:3-oxoacid CoA transferase precursor	HSU62961
Beta-1,2-N-acetylglucosaminyltransferase	HSU15128
Hypoxanthine phosphoribosyltransferase	HUMHPRT
N-acetylglucosaminyltransferase I	HUMGLCNAC
Galactose-1-phosphate uridyl transferase	HUMGALTA
Histo-blood group A transferase (UDP-GalNAc)	HUMUDPG
Terminal transferase	HUMTDTA
Beta 1,4-galactosyl-transferase	HUMGSTE
Glutathione S-transferase subunit 1	HUMLGTH1
Basic helix-loop-helix DNA binding protein (TWIST)	HSU80998
Growth hormone	HUMGH

Bibliography

- Amit, A., Mariuzza, R., Phillips, S., and Poljak, R. (1986). Three dimensional structure of an antigen-antibody complex at 2.8 Å resolution. *Science* 233:747–753.
- Argos, P., Rossmann, M., Grau, U., Zuber, A., Franck, G., and Tratschin, J. (1979). Thermal stability and protein structure. *Biochemistry* 18:5698–5703.
- B-Rao, C. and Stewart, J. (1996). Inverse analysis of empirical matrices of idiotypic network interactions. *Bull. Math. Biol.* 58:1123–1153.
- Bachl, J. and Wabl, M. (1996). An immunoglobulin mutator that targets G.C base pairs. *Proc. Natl. Acad. Sci. USA* 93:851–855.
- Bartlett, M. (1978). *An introduction to stochastic processes*. Cambridge University Press, Cambridge, 3rd edition.
- Beck, G. and Habicht, G. (1996). Immunity and the invertebrates. *Sci. Am.* 275:60–66.
- Berek, C., Berger, A., and Apel, M. (1991). Maturation of the immune response in the germinal centers. *Cell* 67:1121–1129.
- Bernard, O., Hozumi, N., and Tonegawa, S. (1978). Sequences of mouse immunoglobulin light chain gene before and after somatic changes. *Cell* 15:1133–1144.
- Bernardi, G. and Bernardi, G. (1986). Compositional constraints and genome evolution. *J. Mol. Evol.* 22:363–365.
- Betz, A., Rada, C., Pannell, R., Milstein, C., and Neuberger, M. (1993). Passenger transgenes reveal intrinsic specificity of the antibody hypermutation mechanism: clustering, polarity and specific hot spots. *Proc. Natl. Acad. Sci. USA* 90:2385–2388.
- Bill, C., Duran, W., Miselis, N., and Nickoloff, J. (1998). Efficient repair of all types of single-base mismatches in recombination intermediates in Chinese hamster ovary cells. Competition between long-patch and G-T glycosylase-mediated repair of G-T mismatches. *Genetics* 149:1935–1943.
- Brooks, R., Bennett, D., and Smith, J. (1980). Mammalian cell cycles need two random transitions. *Cell* 19:493–504.
- Cairns, J., Overbaugh, J., and Miller, S. (1988). The origin of mutants. *Nature* 335:142–145.
- Carneiro, J. and Stewart, J. (1994). Rethinking "shape space": evidence from simulated docking suggests that steric shape complementarity is not limiting for antibody-antigen recognition and idiotypic interactions. *J. Theor. Biol.* 169:391–402.

- Cascalho, M., Wong, J., Steinberg, C., and Wabl, M. (1998). Mismatch repair co-opted by hypermutation. *Science* 279:1207–1210.
- Cohn, M. and Langman, R. (1990). The protecton: the unit of humoral immunity selected by evolution. *Immunol. Rev.* 115:11–147.
- Cowell, L., Kim, H., Humaljoki, T., Berek, C., and Kepler, T. (1998). Enhanced evolvability in immunoglobulin *v* genes under somatic hypermutation. *J.Molec.Evol.* (to appear) .
- Dal Porto, J., Haberman, A., Shlomchik, M., and Kelsoe, G. (1998). Antigen drives very low affinity B cells to become plasmacytes and enter the germinal centers. *J. Immunol.* 161:5373–5381.
- Davis, M., Boniface, J., Reich, Z., Lyons, D., Hampl, J., Arden, B., and Chien, Y. (1998). Ligand recognition by $\alpha\beta$ T cell receptors. *Annu. Rev. Immunol.* 16:523–544.
- De Boer, R., Segel, L., and Perelson, A. (1992). Pattern formation in one- and two-dimensional shape-space models of the immune system. *J. Theor. Biol.* 155:295–333.
- Derrida, B. (1984). Random-energy model: An exactly solvable model of disordered systems. *Phys. Rev. B* 24:2613–2626.
- Detours, V., Bersini, H., Stewart, J., and Varela, F. (1994). Development of an idiotypic network in shape space. *J. Theor. Biol.* 170:401–414.
- Diaz, M. and Flajnik, M. (1998). Evolution of somatic hypermutation and gene conversion in adaptive immunity. *Immunol. Rev.* 162:13–24.
- Dörner, T., Brezinschek, H., Foster, S., Brezinschek, R., Farner, N., and Lipsky, P. (1998). Delineation of selective influences shaping the mutated expressed human Ig heavy chain repertoire. *J. Immunol.* 160:2831–2841.
- Dörner, T., Brezinschek, H.-P., Foster, S., Domiati–Saad, R., and Lipsky, P. (1997). Analysis of the frequency pattern of somatic mutations within nonproductively rearranged human variable heavy chain genes. *J. Immunol.* 158:2779–2789.
- Dunn-Walters, D., Dogan, A., Boursier, L., MacDonald, C., and Spencer, J. (1998). Base-specific sequences that bias somatic hypermutation deduced by analysis of out-of-frame human IgVH genes. *J. Immunol.* 160:2360–2364.
- Feeney, A. (1992). Predominance of $V_H - D - J_H$ junctions occurring at sites of short sequence homology results in limited junctional diversity in neonatal antibodies. *J. Immunol.* 149:222–229.
- Fisher, R. (1930). *The genetical theory of natural selection*. Oxford University Press.
- Foote, J. and Winter, G. (1992). Antibody framework residues affecting the conformation of the hypervariable loops. *J. Mol. Biol.* 224:487–499.
- Frey, S., Bertocci, B., Delbos, F., Quint, L., Weill, J.-C., and Raynaud, C.-A. (1998). Mismatch repair deficiency interferes with the accumulation of mutations in chronically stimulated B cells and not with the hypermutation process. *Immunity* 9:127–134.
- Gilfillan, S., Bachmann, M., Trembleau, S., Adorini, L., Kalinke, U., Zinkernagel, R., Benoist, C., and Mathis, D. (1995). Efficient immune responses in mice lacking N-region diversity. *Eur. J. Immunol.* 25:3115–3122.

- Gilfillan, S., Dierich, A., Lemeur, M., Benoist, C., and Mathis, D. (1993). Mice lacking TdT: mature animals with an immature lymphocyte repertoire. *Science* 261:1175–1178.
- Giudicelli, V., Chaume, D., Bodmer, J., Muller, W., Busin, C., Marsh, S., Bontrop, R., Marc, L., Malik, A., and M.P., L. (1997). IMGT, the international ImMunoGeneTics database. *Nucleic Acids Res.* 25:206–211.
- Goodlad, J. and Macartney, J. (1995). Regulation of murine germinal centre cell proliferation *in vivo*: A stathmokinetic study examining the effect of differently timed doses of cyclosporin A. *J. Pathol.* 176:87–97.
- Hanna, M. (1964). An autoradiographic study of the germinal center in spleen white pulp during early intervals of the immune response. *Lab. Invest.* 13:95–104.
- Higgins, D. and Sharp, P. (1988). CLUSTAL: a package for performing multiple sequence alignments on a microcomputer. *Gene* 73:237–244.
- Hightower, R. (1996). *Computational aspect of antibody gene families*. Ph.D. thesis, University of New Mexico.
- Hinds-Frey, K., Nishikata, H., Litman, R., and Litman, G. (1993). Somatic variation precedes extensive diversification of germline sequences and combinatorial joining in the evolution of immunoglobulin heavy chain diversity. *J. Exp. Med.* 178:815–824.
- Hsu, E. (1998). Mutation, selection, and memory in b lymphocytes of exothermic vertebrates. *Immunol. Rev.* 162:25–36.
- Huisman, G., Siegele, D., Zambrano, M., and Kolter, R. (1996). Morphological and physiological changes during stationary phase. In *Escherichia coli and Salmonella*, F. Neidhardt, ed., pp. 1672–1682. ASM Press, Washington, D.C.
- Ikemura, T. (1981). Correlation between the abundance of Escherichia coli transfer RNAs and the occurrence of the respective codons in its protein genes: a proposal for a synonymous codon choice that is optimal for the E. coli translational system. *J. Mol. Evol.* 151:389–409.
- Ikemura, T. (1985). Codon usage and tRNA content in unicellular and multicellular organisms. *Mol. Biol. Evol.* 2:13–34.
- Insel, R., Adderson, E., and Carroll, W. (1992). The repertoire of human antibody to the *Haemophilus influenzae* type b capsular polysaccharide. *Int. Rev. Immunol.* 9:25–42.
- Insel, R. and Varade, W. (1998). Characteristics of somatic hypermutation of human immunoglobulin genes. *Curr. Top. Microbiol. Immunol.* 229:33–44.
- Jacob, J., Kassir, R., and Kelsoe, G. (1991). In situ studies of the primary immune response to (4-hydroxy-3-nitrophenyl)acetyl. I. The architecture and dynamics of responding cell populations. *J. Exp. Med.* 173:1165–1175.
- Jacob, J. and Kelsoe, G. (1992). In situ studies of the primary immune response to (4-hydroxy-3-nitrophenyl)acetyl. II. A common clonal origin for periarteriolar lymphoid sheath-associated foci and germinal centers. *J. Exp. Med.* 176:679–687.

- Jones, M., Thomas, S., and Rogers, A. (1994). Luria-Delbrück fluctuation experiments: design and analysis. *Genetics* 136:1209–1216.
- Kearney, J., Bartels, J., Hamilton, A., Lehuen, A., Solvason, N., and Vakil, M. (1992). Development and function of the early B cell repertoire. *Intern. Rev. Immunol.* 8:247–257.
- Kelly, C. and Rahn, O. (1932). The growth of individual bacterial cells. *J. Bacteriol.* 23:147–153.
- Kelsoe, G. (1998). V(D)J hypermutation and DNA mismatch repair: Vexed by fixation. *Proc. Natl. Acad. Sci. USA* 95:6576–6577.
- Kendall, D. (1948). On the role of variable generation time in the development of a stochastic birth process. *Biometrika* 35:316–330.
- Kendall, D. (1952). Les processus stochastiques de croissance in biologie. *Ann. Inst. H. Poincaré* 13:43–108.
- Kepler, T. (1997). Codon bias and plasticity in immunoglobulins. *Mol. Biol. Evol.* 14:637–643.
- Kepler, T. and Bartl, S. (1998). Plasticity under somatic mutation in antigen receptors. *Curr. Top. Microbiol. Immunol.* 229:149–162.
- Kepler, T. and Perelson, A. (1993). Cyclic re-entry of germinal center B cells and the efficiency of affinity maturation. *Immunol. Today* 14:412–415.
- Knuth, D. (1973). *The art of computer programming, vol. 2*. Addison-Wesley Publishing Company, Inc.
- Kroese, F., Wubenna, A., Seijen, H., and Nieuwenhuis, P. (1987). Germinal centers develop oligoclonally. *Eur. J. Immunol.* 17:1069–1072.
- Langman, R. and Cohn, M. (1993). Two signal models of lymphocyte activation? *Immunol. Today* 14:235–237.
- Lea, D. and Coulson, C. (1949). The distribution of the number of mutants in bacterial populations. *J. Genetics* 49:264–284.
- Lebecque, S. and Gearhart, P. (1990). Boundaries of somatic mutation in rearranged immunoglobulin genes: 5' boundary is near the promoter, and 3' boundary is approximately 1 kb from V(D)J gene. *J. Exp. Med.* 172:1717–1727.
- Lee, W., Cosenza, H., and Köhler, H. (1974). Clonal restriction of the immune response to phosphorylcholine. *Nature* 247:55–61.
- Li, W.-H. (1997). *Molecular evolution*. Sinauer Associates, Inc. Sunderland Massachusetts 01375 USA.
- Liu, Y. J., Zhang, J., Lane, P. J. L., Chan, E. Y.-T., and MacLennan, I. C. M. (1991). Sites of specific B cell activation in primary and secondary responses to T cell-dependent and T cell-independent antigens. *Eur. J. Immunol.* 21:2951–2962.
- Luria, S. and Delbrück, M. (1943). Mutations of bacteria from virus sensitivity to virus resistance. *Genetics* 28:491–511.

- MacLennan, I. (1991). The centre of hypermutation. *Nature* 354:352–353.
- MacLennan, I. C. M. (1994). Germinal centers. *Annu. Rev. Immunol.* 12:117–139.
- MacLennan, I. C. M., Liu, Y. J., Olfield, S., Zhang, J., and Lane, P. J. L. (1990). The evolution of B-cell clones. *Curr. Top. Microbiol. Immunol.* 159:37–63.
- MacWilliams, F. and Sloane, N. (1986). *The theory of error correcting codes*. Elsevier Science Publishers, B.V.
- Matzinger, P. (1994). Tolerance, danger and the extended family. *Annu. Rev. Immunol.* 12:991–1045.
- McKean, D. M., Huppi, K., Bell, M., Staudt, L., Gerhard, W., and Weigert, M. (1984). Generation of antibody diversity in the immune response of BALB/c mice to influenza virus hemagglutinin. *Proc. Natl. Acad. Sci. USA* 81:3180–3184.
- Milstein, C., Neuberger, M., and Staden, R. (1998). Both DNA strands of antibody genes are hypermutation targets. *Proc. Natl. Acad. Sci. USA* 95:8791–8794.
- Minar, N. (1994). Suboptimal solutions in a simple GA problem and the underuse of genetic material (unpublished manuscript). <http://www.santafe.edu/nelson/gaimmune> .
- Mitchell, M. (1996). *An introduction to genetic algorithms*. The MIT Press, Cambridge, Massachusetts.
- Motoyama, N., Okada, H., and Azuma, T. (1991). Somatic mutation in constant regions of mouse λ_1 light chains. *Proc. Natl. Acad. Sci. USA* 88:7933–7937.
- Nossal, G. (1971). *Antibodies and immunity*. Pelican Books, Ltd., Harmondsworth, Middlesex, England.
- Nossal, G. (1992). The molecular and cellular basis of affinity maturation in the antibody response. *Cell* 68:1–2.
- Oprea, M. and Perelson, A. (1997). Somatic mutation leads to efficient affinity maturation when centrocytes recycle back to centroblasts. *J. Immunol.* 158:5155–5162.
- Perelson, A. (1989). Immune network theory. *Immunol. Rev.* 110:5–36.
- Perelson, A. and Oster, G. (1979). Theoretical studies of clonal selection: minimal antibody repertoire size and reliability of self-non-self discrimination. *J. Theor. Biol.* 81:645–670.
- Phung, Q., Winter, D., Cranston, A., Tarone, R., Bohr, V., Fishel, R., and Gearhart, P. (1998). Increased hypermutation at G and C nucleotides in immunoglobulin variable genes from mice deficient in the MSH2 mismatch repair protein. *J. Exp. Med.* 187:1745–1751.
- Press, W., Flannery, B., Teukolsky, S., and Vetterling, W. (1988). *Numerical recipes in C*. Cambridge University Press, Cambridge.
- Radmacher, M., Kelsoe, G., and Kepler, T. (1998). Predicted and inferred waiting times for key mutations in the germinal center reaction: Evidence for stochasticity in selection. *Immunol. Cell Biol.* 76:373–381.

- Reynaud, C., Garcia, C., and J.C., W. (1995). Hypermutation generating the sheep immunoglobulin repertoire is an antigen-independent process. *Cell* 80:115–125.
- Rogozin, I. and Kolchanov, N. (1992). Somatic hypermutagenesis in immunoglobulin genes. II. Influence of neighboring base sequences on mutagenesis. *Biochim. Biophys. Acta* 1171:11–18.
- Roux, K., Greenberg, A. S., Greene, L., Strelets, L., Avila, D., McKinney, E., and Flajnik, M. (1998). Structural analysis of the nurse shark (new) antigen receptor (NAR): Molecular convergence of NAR and unusual mammalian immunoglobulins. *Proc. Natl. Acad. Sci. USA* 95:11804–11809.
- Sarkar, S. A. (1992). On fluctuation analysis: a new, simple and efficient method for computing the expected number of mutants. *Genetica* 85:173–179.
- Segel, L. and Perelson, A. (1989). Shape space: an approach to the evaluation of cross-reactivity effects, stability and controllability in the immune system. *Immunol. Lett.* 22:91–99.
- Seidman, J., Leder, A., Edgell, M., Polsky, F., Tilghman, S., Tiemeier, D., and Leder, P. (1978). Multiple related immunoglobulin variable region genes identified by cloning and sequence analysis. *Proc. Natl. Acad. Sci. USA* 75:3881–3885.
- Smith, D., Creadon, G., Jena, P., Portanova, J., Kotzin, B., and Wysocki, L. (1996). Di- and trinucleotide target preferences in somatic mutagenesis in normal and autoreactive B cells. *J. Immunol.* 156:2642–2652.
- Smith, D., Forrest, S., Hightower, R., and Perelson, A. (1997). Deriving shape space parameters from immunological data. *J. Theor. Biol.* 189:141–150.
- Smith, J. and Martin, L. (1973). Do cells cycle? *Proc. Natl. Acad. Sci. USA* 70:1263–1267.
- Stewart, F., Gordon, D., and Levin, B. (1990). Fluctuation analysis: the probability distribution of the number of mutants under different conditions. *Genetics* 124:175–185.
- Van der Stoep, N., Van der Linden, J., and Logtenberg, T. (1993). Molecular evolution of the human immunoglobulin E response: high incidence of shared mutations and clonal relatedness among V_{H5} transcripts from three unrelated patients with atopic dermatitis. *J. Exp. Med.* 177:99–107.
- Takahashi, Y., Dutta, P., Cerasoli, D., and Kelsoe, G. (1998). In situ studies of the primary immune response to (4-hydroxy-3-nitrophenyl)acetyl. V. Affinity maturation develops in two stages of clonal selection. *J. Exp. Med.* 187:885–895.
- Tanaka, T. and Nei, M. (1989). Positive Darwinian selection observed at the variable region genes of immunoglobulins. *Mol. Biol. Evol.* 6:447–459.
- Tew, J. and Mandel, T. (1979). Prolonged antigen half-life in the lymphoid follicles of specifically immunized mice. *Immunology* 37:69–76.
- Tew, J., Mandel, T., and Miller, G. (1979). Immune retention: immunological requirements for maintaining an easily degradable antigen in vivo. *Australian J. Exp. Biol. Med. Sci.* 57:401–414.
- Tonegawa, S. (1983). Somatic generation of antibody diversity. *Nature* 302:575–581.
- Torkelson, J., Harris, R., Lombardo, M., Nagendran, J., Thulin, C., and Rosenberg, M. (1997). Genome-wide hypermutation in a subpopulation of stationary-phase cells underlies recombination-dependent adaptive mutation. *EMBO J.* 16:3303–3311.

- Travisano, M. and Lenski, R. (1996). Long-term experimental evolution in *Escherichia coli*. IV. Targets of selection and the specificity of adaptation. *Genetics* 143:15–26.
- Van Zoelen, E., Van Der Saag, P., and De Laat, S. (1981). Family tree analysis of a transformed cell line and the transition probability model for the cell cycle. *Exp. Cell Res.* 131:395–406.
- Varade, W., Carnahan, J., Kingsley, P., and Insel, R. (1998). Inherent properties of somatic hypermutation as revealed by human non-productive VH6 immunoglobulin rearrangements. *Immunology* 93:171–176.
- Varade, W., Marin, E., Kittelberger, A., and Insel, R. (1993). Use of the most proximal J_H -proximal human Ig H chain V region gene, V_H6 in the expressed immune repertoire. *J. Immunol.* 150:4985–4995.
- Wagner, S., Milstein, C., and Neuberger, M. (1995). Codon bias targets mutation. *Nature* 376:732.
- Weigert, M., Cesari, I., Yonkovitch, S., and Cohn, M. (1970). Variability in the light chain sequences of mouse antibody. *Nature* 228:1045–1047.
- Wilson, M., Hsu, E., Marcuz, A., Courtet, L., Du Pasquier, L., and Steinberg, C. (1992). What limits affinity maturation of antibodies in *Xenopus* - the rate of somatic mutation or the ability to select mutants? *EMBO J.* 11:4337–4347.
- Winter, D., Phung, Q., Umar, A., Baker, S., Tarone, R., Tanaka, K., Liskay, R., Kunkel, T., Bohr, V., and Gearhart, P. (1998). Altered spectra of hypermutation in antibodies from mice deficient for the DNA mismatch repair protein PMS2. *Proc. Natl. Acad. Sci. USA* 95:6953–6958.
- Wolfe, K., Sharp, P., and Li, W.-H. (1989). Mutation rates differ among regions of the mammalian genome. *Nature* 337:283–285.
- Wu, T. and Kabat, E. (1970). An analysis of the sequences of the variable regions of the Bence-Jones proteins and myeloma light chains and their implications for antibody complementarity. *J. Exp. Med.* 132:211–250.
- Zhang, J., MacLennan, I., Liu, Y.-J., and Lane, P. (1988). Is rapid proliferation in B centroblasts linked to somatic mutation in memory B-cell clones? *Immunol. Lett.* 18:297–299.
- Zheng, B., Xue, W., and Kelsoe, G. (1994). Locus-specific somatic hypermutation in germinal centre T cells. *Nature* 372:556–559.
- Zuber, H. (1981). Structure and function of thermophilic enzymes. In *Structural and functional aspects of enzyme catalysis*, H. Eggerer and R. Huber, eds., pp. 114–127. Springer-Verlag, Berlin.